

Operation and Installation Manual



Accumulation Tank

NAD 250 v 1



Družstevní závody Dražice-strojírna s.r.o.
(Works Cooperative - Dražice - Machine Plant, Ltd.)

Dražice 69

294 71 Benátky nad Jizerou

Tel.: 326 370 911, fax: 326 370 980

www.dzd.cz

dzd@dzd.cz

1. Description

Accumulation tanks serve accumulation of excessive heat from its source. The source may be a solid fuel boiler, heat pump, solar collectors, fireplace inserts, etc.

The NAD type tanks serve storage of heat in the heating system only. Incorporation of an accumulation tank in the heating system with a solid fuel boiler allows an ideal run of a boiler at favourable temperature during the boiler operation. The main benefit lies in the period of optimum operation (i.e. with maximum efficiency) when the excessive unconsumed heat accumulates in the tank.

The tanks are made of a steel plate and tested by 0.9 MPa overpressure, without any inner surface treatment. The tank is insulated with polyurethane CFCs-free insulation of 42 mm thickness with perfect thermally insulating properties. The outer shell is made of steel sheet provided with a powder coating.

Installation principles

The NAD accumulation tank is designed as stationary for vertical fitting to a fixed floor.

The tanks are not designed for accumulation of HSW – hot service water.

2. Designing the size and connection of ACCU tank to the heating system

An ideal size of the accumulation tank is designed by a design engineer, or a person sufficiently qualified to design heating systems.

Product assembly must be implemented by an authorised person (confirmed in the warranty certificate).

3. General Technical Parameters

	NAD 250 v 1
Tank capacity (l)	250
Outer tank diameter (mm)	584
Height of tank (mm)	1573 ^{±2}
Max tank pressure (MPa)	0.3
Max temperature of heating water in the tank (°C)	90

4. General dimensions

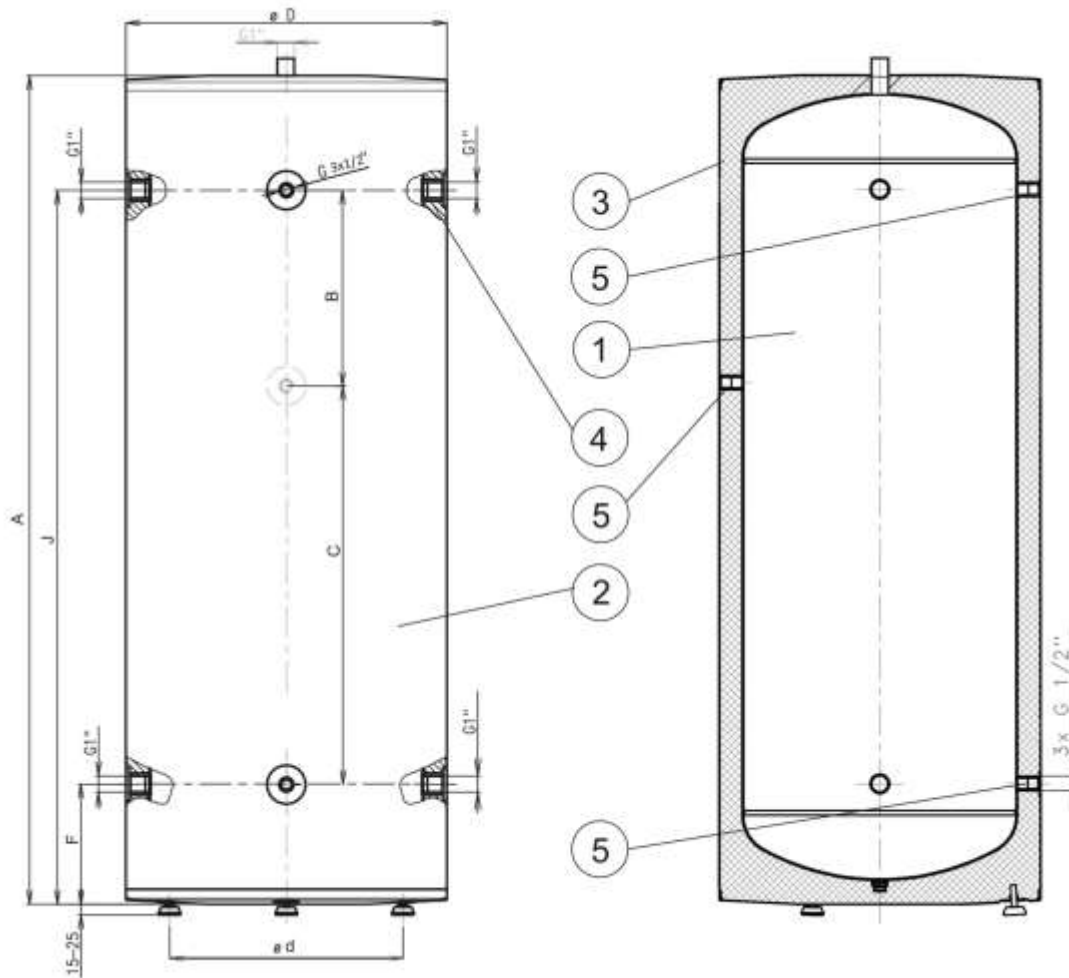

1. Steel receptacle
2. Tank shell
3. Polyurethane CFCs-free insulation 42 mm
4. Funnel G 1" for connecting heating water supply - 4 pcs
5. Funnel G 1/2" for connecting a thermowell - 3 pcs

A	B	C	d	D	F	J
1573 ^{±2}	356	724	490	584	230	1310

RECOMMENDATION

It is recommended to use the product in an indoor environment with air temperatures from +5°C to 45°C and relative humidity up to 80%.

Prior to commissioning, we recommend that you run the heating circuit and any impurities that are trapped in the filter clean, then the system is fully operational.