

OPERATING AND INSTALLATION MANUAL

Accumulation Tank

NAD 100 v1

NAD 250 v1



Družstevní závody Dražice - strojírna s.r.o.
Dražice 69, 294 71 Benátky nad Jizerou
Phone.: +420 / 326 370 990
Fax: +420 / 326 370 980
e-mail: prodej@dzd.cz

 **Cerbos**
küttesüsteemid • müük • paigaldus • hooldus
tel 442 0222 / 434 1000 • www.cerbos.ee • info@cerbos.ee

 **DRAŽICE**
ČLEN SKUPINY NIBE

CONTENTS

1	DESCRIPTION	3
2	THE DESIGN OF SUITABLE VOLUME AND TANK INSTALLATION	4
3	TECHNICAL PARAMETERS.....	4
4	INFORMATION SHEET	4
5	DIMENSIONS AND CONNECTION	5
6	DISPOSAL OF PACKAGING MATERIAL AND NON-FUNCTIONING PRODUCT.....	7

PRIOR TO THE INSTALLATION OF THE TANK, READ CAREFULLY THIS MANUAL!

Dear customer,

The Works Cooperative of Dražice – Machine Plant, Ltd., would like to thank you for your decision to use a product of our brand.

The manufacturer reserves the right for engineering modification of the product.

The product is designed for permanent contact with drinkable water.



1 DESCRIPTION

Accumulation tanks serve for the **accumulation of excessive energy from the heat source**. The source may be a solid fuel boiler, heat pump, fireplace inserts, etc.

The NAD type tanks serve for the accumulation of heat in the heating system; the operation agent is heating water. The accumulation tank inclusion in the heating system with the heat source provides ideal operation of the heat source under beneficial temperature conditions. The main benefit is the optimising of the heat source operation (i.e. with maximum efficiency) when the unconsumed heat accumulates in the tank.

The tanks are made of a steel plate and tested by 1.5 MPa multiple of operation pressure value, without any inner surface treatment. NAD 100 v1 and NAD 250 v1 are insulated with hard polyurethane Freon-free foam with 42 mm thickness, with great insulation ability. Top housing is made of sheet metal and with powder paint surface finish.

The installation conditions

NAD 100 v1 is stationary and suspension accumulation tank for vertical installation on solid, sufficiently bearing base or wall. NAD 250 v1 is only stationary tank for vertical installation on solid, sufficiently bearing base or wall.

Accumulation tanks NAD 100 v1 and NAD 250 v1 cannot be used for accumulation of TV – drinking water.

2 THE DESIGN OF SUITABLE VOLUME AND TANK INSTALLATION

The design of the accumulation tank volume is performed by the heating designer or a person sufficiently qualified for the design of the heating systems.

Installation of NAD 100 v1 and NAD 250 v1 must be performed by a specialist plumber who will confirm the fact by a stamp in the warranty sheet.

3 TECHNICAL PARAMETERS

	NAD 100 v1	NAD 250 v1
Tank diameter [mm]	584	584
Height [mm]	807	1572
Maximum operating pressure [MPa]	0,3	0,3
Maximum heating water temperature [°C]	90	90
Maximum output of additional heating element Tj 6/4" [kW]	6	6

4 INFORMATION SHEET

	NAD 100 v1	NAD 250 v1
Energy efficiency class	B	C
Static loss [W]	42	42
Tank capacity [l]	120	265

5 DIMENSIONS AND CONNECTION

NAD 100 v1

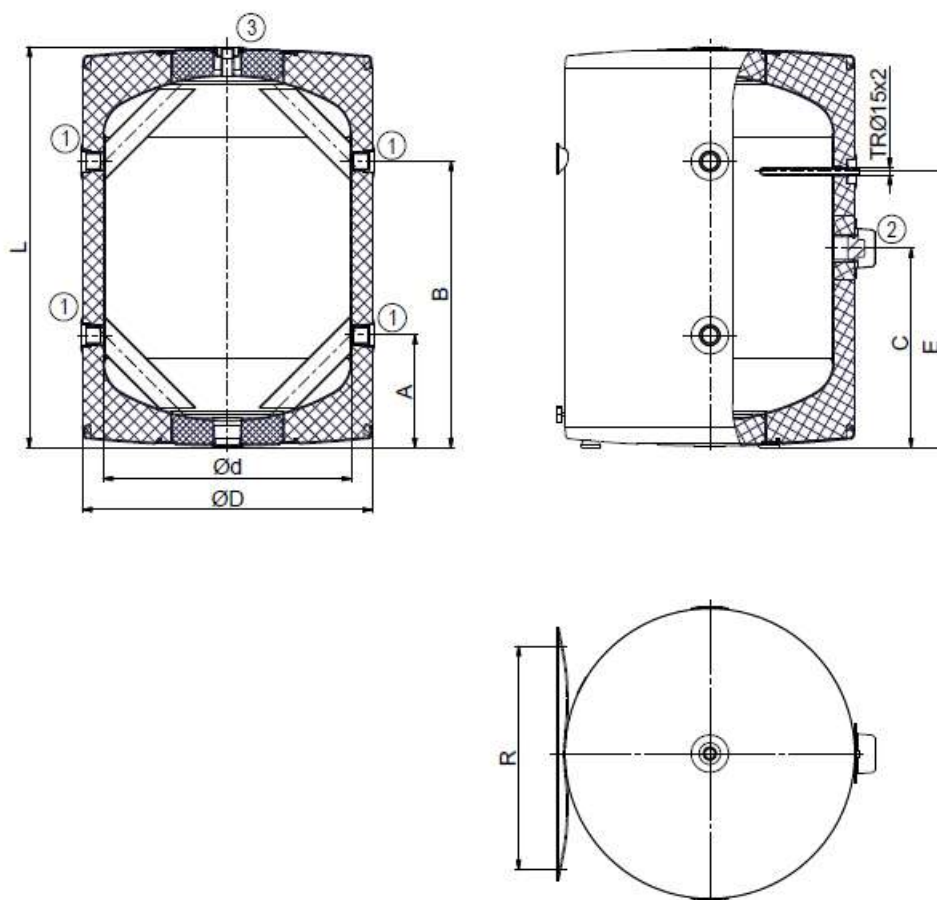

1. Hot water inlet/ outlet - G 1"
2. Inlet for the installation of electrical heating unit TJ 6/4" - G 1 1/2"
3. Deaerating – G1/2"

A	B	C	d	D	E	L	R
226	576	401	500	584	556	807	300-310 350-372 432-468

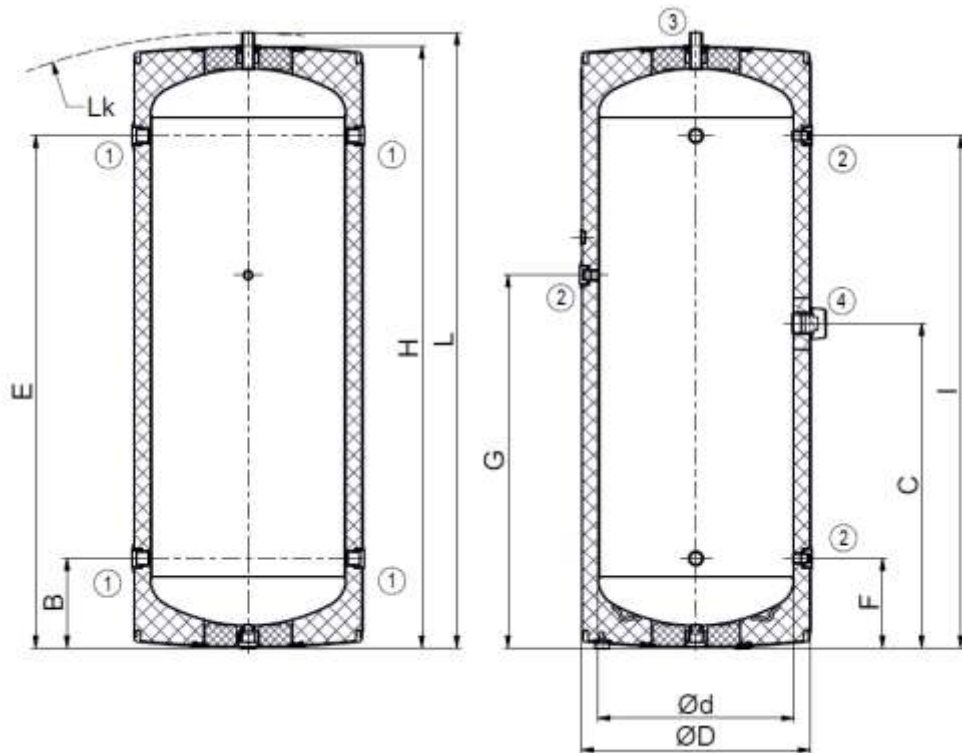

1. Hot water inlet/ outlet - G 1"
2. Heating water drainage – G1/2"
3. Hot water inlet/ outlet - G 1"
4. Inlet for the installation of electrical heating unit TJ 6/4" - G 1 ½"

B	C	d	D	E	F	G	H	I	L	L _k	R
228	828	500	584	1308	228	952	1565	1308	1572	1607	300-310 350-372 432-468

Recommendation

Prior to commissioning we recommend leaving the heating circuit circulation pump in operation for the period of at least 24 hours. Potential contamination from the system is arrested in the filter. After the filter cleaning, the system is fully operable.

6 DISPOSAL OF PACKAGING MATERIAL AND NON-FUNCTIONING PRODUCT

A service fee for providing return and recovery of packaging material has been paid for the packaging in which the product was delivered. The service fee was paid pursuant to Act No 477/2001 Coll., as amended, at EKO-KOM a.s. The client number of the company is F06020274. Take the water tank packages to a waste disposal place determined by the municipality. When the operation terminates, disassemble and transport the discarded and unserviceable heater to a waste recycling centre (collecting yard), or contact the manufacturer.



6-12-2016



küttesüsteemid • müük • paigaldus • hooldus
Paide mnt 7, Pärnu 80042, Eesti • www.cerbos.ee