

# Order spare parts under correct spare part codes

## Contens

<b>1. General spare parts</b>	<b>3</b>
<b>2. Wood gasification DCxxS, GS, wood burning Dxx, pellet DxxP or natural gas or LFO boilers typ EP(L), SP(L)</b>	<b>25</b>
<b>3. Coal and wood gasification boilers</b>	<b>32</b>
<b>4. Accessories</b>	<b>35</b>
<b>5. Pellet burner ATMOS A25</b>	<b>46</b>
<b>6. Pellet burner ATMOS A45</b>	<b>53</b>
<b>7. Pellet burner IWABO</b>	<b>60</b>
<b>8. Pellet burner ERATO GP20</b>	<b>63</b>
<b>9. Pellet burner ATMOS A50</b>	<b>66</b>
<b>10. Automatic ash removal for boilers DxxP</b>	<b>71</b>
<b>11. LFO and Natural gas burners</b>	<b>72</b>



# 1. General spare parts

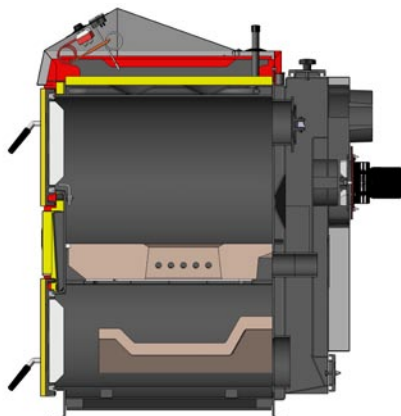

## Regulating boiler thermostat – controls fan



Without black knob

<b>Code: S0021</b> 40 - 95°C – all boilers - standard type	<i>Price:</i>
	<i>Weight:</i> 0,10 kg
<b>Code: S0024</b> 40 - 95°C – for DC75SE with a longer capillary	<i>Price:</i>
	<i>Weight:</i> 0,10 kg
<b>Code: S0022</b> to 110°C – suitable for fitting boilers with buffer tanks	<i>Price:</i>
	<i>Weight:</i> 0,10 kg
<b>Code: S0025</b> to 110°C - for DC75SE - longer capillary (Swedish performance)	<i>Price:</i>
	<i>Weight:</i> 0,10 kg

## Regulating boiler pump thermostat



Without knob

<b>Code: S0023</b> with three pins with shaft for knob - for boilers DC15E, D15, D20, D30, D15P, D20P, D30P, D45P, DC15EP(L), DC14R	<i>Price:</i>
	<i>Weight:</i> 0,10 kg
<b>Code: S0062</b> with three pins without shaft (controlled by screw driver) for boilers DC18SP(L), DC25SP(L), DC32SP(L)	<i>Price:</i>
	<i>Weight:</i> 0,10 kg

## Waste gas thermostat

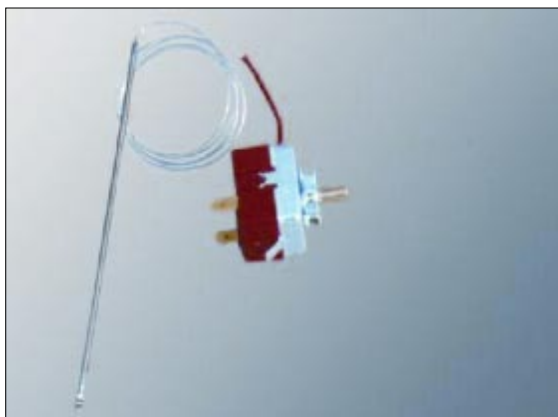

<b>Code: S0031</b> -15 to 300°C - switches off ventilator after fuel has been burned out	<i>Price:</i>
	<i>Weight:</i> 0,10 kg
<b>Code: S0019</b> -15 to 300°C – for DC75SE – with a longer capillary	<i>Price:</i>
	<i>Weight:</i> 0,10 kg
<b>Code: S0034</b> tool kit for upgrading old bo- iler and installing waste gas thermostat	<i>Price:</i>
	<i>Weight:</i> 0,10 kg

## Waste gas thermostat without shaft (0 - 300°C)

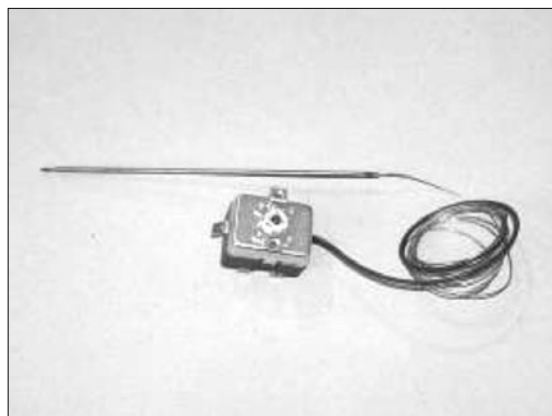

<b>Code: S0020</b> it serves to close the servomotor Belimo when exceeding the set temperature of waste gas - for DC18GSE - DC50GSE	<i>Price:</i>
	<i>Weight:</i> 0,08 kg

### Safety irreversible thermostat

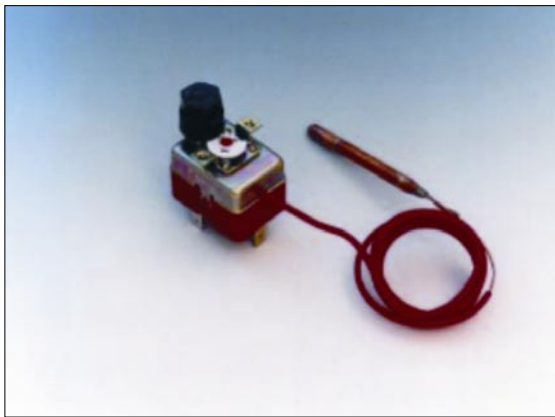

**Code: S0061** 90 - 110°C standard – built in the main control panel of the boiler

*Price:*  
*Weight:* 0,12 kg

**Code: S0068** 110°C - dual-circuit - built in the main control panel of the pellets boilers – for DxxP, DCxxSP(L), EP(L) - from serial number 168800

*Price:*  
*Weight:* 0,12 kg

### Black Knob



**Code: S0032** black knob for boiler thermostats in the main control panel

*Price:*  
*Weight:* 0,02 kg

### Thermometer



**Code: S0041** For all ATMOS boilers

*Price:*  
*Weight:* 0,06 kg

**Code: S0056** for DC75SE with a longer capillary

*Price:*  
*Weight:* 0,12 kg

### Manometer - DC100



**Code: S0044** manometer to the boiler panel DC100

*Price:*  
*Weight:* 0,10 kg

### Safety reversible thermostat TH480RB



**Code: S0051** 98°C – built in boiler – for old boiler types

*Price:*  
*Weight:* 0,10 kg

### Boiler pump thermostat



**Code: S0052** 70°C – preset – old types of boilers and for boilers DC100, DC75SE

*Price:*  
*Weight:* 0,10 kg

**Code: S0053** 90°C (95°C) - preset – for EU boilers and for boilers DC100, DC75SE

*Price:*  
*Weight:* 0,10 kg

### Grommets

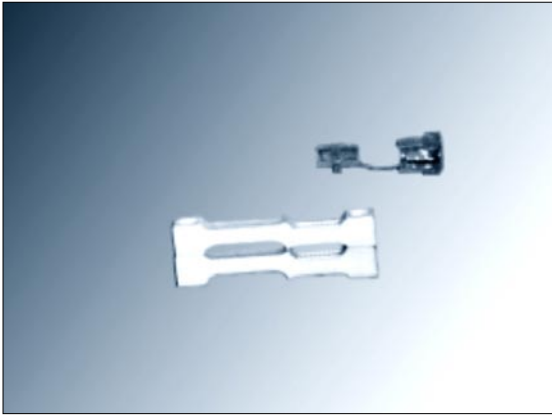

<b>Code: S0185</b> round grommet	<i>Price:</i>
	<i>Weight: 0,04 kg</i>
<b>Code: S0186</b> flat grommet	<i>Price:</i>
	<i>Weight: 0,04 kg</i>

### Terminal block – new type

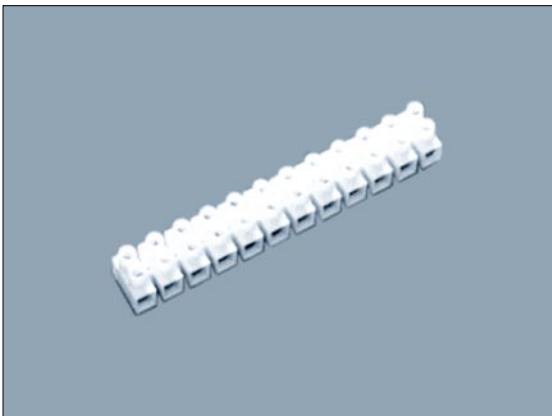

<b>Code: S0182</b> plastic terminal block	<i>Price:</i>
	<i>Weight: 0,08 kg</i>

### Set for controlling pump in the primary circuit



<b>Code: S0516</b> the set is for controlling pump in the primary boiler circuit by waste gas thermostat built in the dash board of the boiler. The set consists of incoming cable with connector and safety thermostat for pump 95°C	<i>Price:</i>
	<i>Weight: 0,28 kg</i>

### Electrical equipment

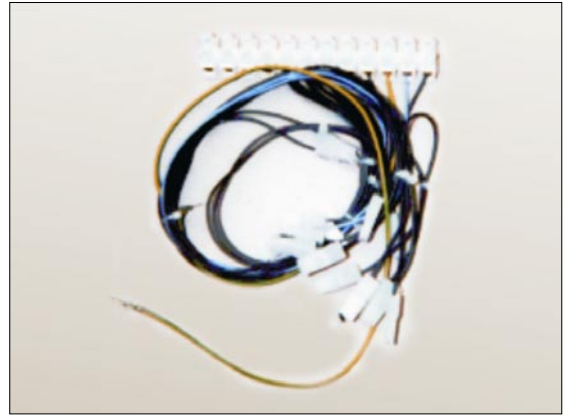

Shown in table no. 1 page 21	
Connecting cabling with terminal box for all types of currently produced types of boilers including cable to the fan	
<b>Code: S0631</b> Flexa wire 2,8 m – incoming cable	<i>Price:</i>
	<i>Weight: 0,17 kg</i>
<b>Code: S0715</b> 2.5 m power cord with <b>3-pin connector</b> for connection of the boiler or pump - <b>new version</b>	<i>Price:</i>
	<i>Weight: 0,15 kg</i>
<b>Code: S0611</b> 2.5 m power cord without connector	<i>Price:</i>
	<i>Weight: 0,13 kg</i>
<b>Code: S0612</b> 2.5 m power cord for pump without connector	<i>Price:</i>
	<i>Weight: 0,10 kg</i>

### End switch with a reversible button



<b>Code: S0094</b> for boilers DC15EP(L), DC18SP(L), DC25SP(L), DC32SP(L)	<i>Price:</i>
	<i>Weight: 0,10 kg</i>

### End switch – DC100



<b>Code: S0075</b> only for DC100 boilers	<i>Price:</i>
	<i>Weight: 0,22 kg</i>

### New connectors for boilers with burner (pellet, ...)

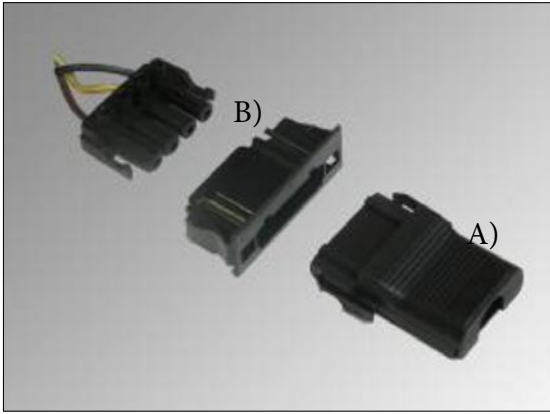

<b>Code: S0633</b> A) male connector - 4-pin	<i>Price:</i>
	<i>Weight: 0,02 kg</i>
<b>Code: S0632</b> B) female connector - 4-pin	<i>Price:</i>
	<i>Weight: 0,02 kg</i>
<b>Code: S0901</b> A) male connector - 5-pin	<i>Price:</i>
	<i>Weight: 0,02 kg</i>
<b>Code: S0913</b> B) female connector - 5-pin	<i>Price:</i>
	<i>Weight: 0,02 kg</i>

### Connectors for electricity income from 1.2.2008

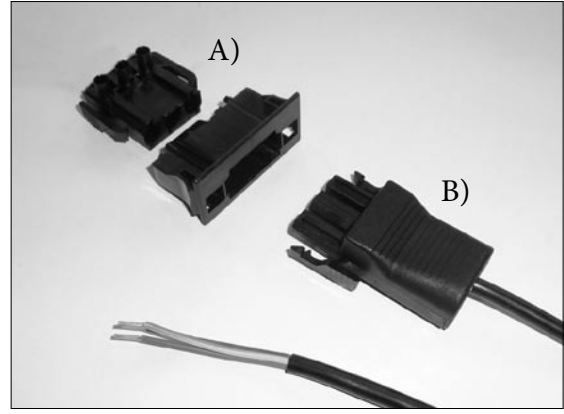

<b>Code: S0641</b> A) male connector with bushing	<i>Price:</i>
	<i>Weight: 0,01 kg</i>
<b>Code: S0640</b> B) female connector for cable	<i>Price:</i>
	<i>Weight: 0,01 kg</i>
<b>Code: S0715</b> incoming cable 2,5 m with connector type B) (S0640)	<i>Price:</i>
	<i>Weight: 0,15 kg</i>

### Connector for boilers with burner

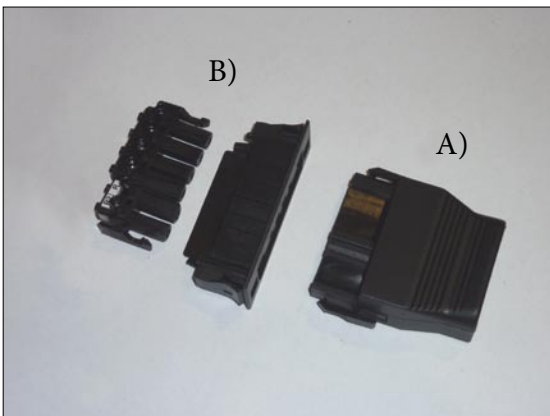

<b>Code: S0985</b> A) male with lid – 6-pin connector	<i>Price:</i>
	<i>Weight: 0,02 kg</i>
<b>Code: S0986</b> B) female with bushing – 6-pin connector	<i>Price:</i>
	<i>Weight: 0,02 kg</i>

### Pocket and fuse for pellet boilers



<b>Code: S0184</b> pocket for fuse in the control panel of the pellet boiler DxxP, DCxxSP, boilers with unit ACD01	<i>Price:</i>
	<i>Weight: 0,01 kg</i>
<b>Code: S0200</b> fuse T6,3A/1500-type H	<i>Price:</i>
	<i>Weight: 0,01 kg</i>

### Old switch

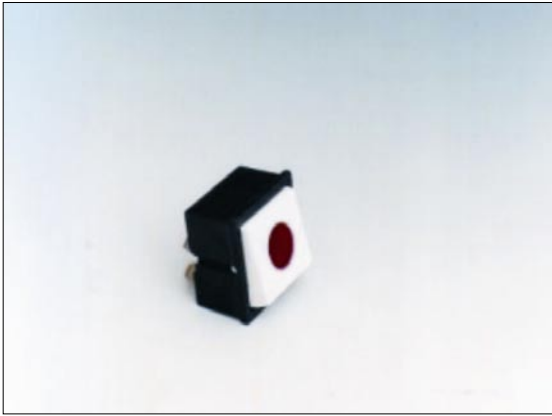

<b>Code: S0081</b> old switch	<i>Price:</i>
	<i>Weight: 0,06 kg</i>
<b>Code: S0082</b> fitting spring	<i>Price:</i>
	<i>Weight: 0,01 kg</i>

### Capacitor for radial fans 3μF

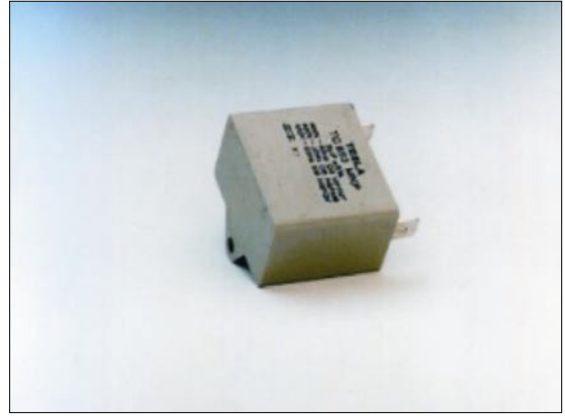

<b>Code: S0101</b> for all radial blowing fans KORA	<i>Price:</i>
	<i>Weight: 0,06 kg</i>

### Capacitor of the extraction fan



<b>Code: S0171</b> for fan UCJ4C52 - 1μF	<i>Price:</i>
	<i>Weight: 0,06 kg</i>
<b>Code: S0173</b> for fan UCJ4C82 - 2μF	<i>Price:</i>
	<i>Weight: 0,06 kg</i>
<b>Code: S0175</b> for fan UCJ4C52A - 4μF - 120V	<i>Price:</i>
	<i>Weight: 0,06 kg</i>

### New switch



<b>Code: S0091</b> new type – green	<i>Price:</i>
	<i>Weight: 0,04 kg</i>
<b>Code: S0093</b> new type–orange – D20P, DC15EP(L)	<i>Price:</i>
	<i>Weight: 0,04 kg</i>
<b>Code: S0096</b> changeover switch (I, O, II) DCxxSP(L)	<i>Price:</i>
	<i>Weight: 0,04 kg</i>
<b>Code: S0098</b> doubleswitch blaf for pellets boilers DxxP	<i>Price:</i>
	<i>Weight: 0,04 kg</i>

### Bearing for fan



<b>Code: S0142</b> spare bearing for exhaust fan UCJ4Cxx - not for ordinary user - can not be easily replaced	<i>Price:</i>
	<i>Weight: 0,02 kg</i>

### Extraction fan UCJ4C52/UCJ4C52A-USA

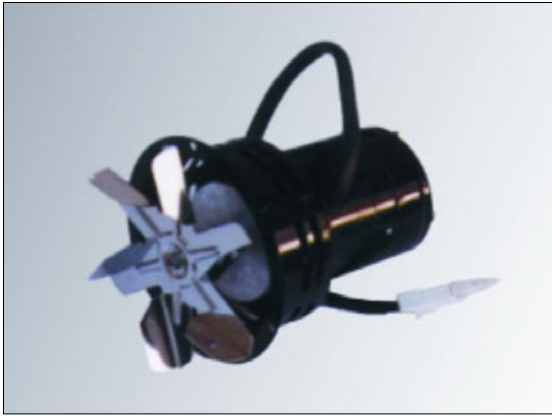

<b>Code: S0131</b> motor 230V/50Hz – for boilers DC18S – DC50S, C18S – C50S, ACxxS, DC18SP(L) – DC32SP(L), DC18GSE – DC50GSE, DC22SX – DC40SX, DxxP, Pxx, DCxxRS, DC50GSX, DC60GSX3, DCxxGS, GSxx, GSxxx	<i>Price:</i>
	<i>Weight: 2,64 kg</i>

<b>Code: S0135</b> motor for USA 120V/60Hz – for boilers DC18S – DC50S, C18S – C50S, ACxxS, DC18SP(L) – DC32SP(L), DC18GSE – DC50GSE, DC22SX – DC40SX, DxxP, Pxx, DCxxRS, DC50GSX, DC60GSX, DCxxGS, GSxx, GSxxx	<i>Price:</i>
	<i>Weight: 4,00 kg</i>

<b>Code: S0133</b> motor with impeller Ø 150 and plate	<i>Price:</i>
	<i>Weight: 3,98 kg</i>

<b>Code: S0134</b> motor with impeller Ø 175 open type and plate	<i>Price:</i>
	<i>Weight: 4,10 kg</i>

<b>Code: S0139</b> motor with impeller Ø 175 closed type – (DC50SE, DC50S, DC50GSX, DC60GSX, DC50GSE, C40S, C50S)	<i>Price:</i>
	<i>Weight: 4,30 kg</i>

### Pressure fan RATAS 3132



<b>Code: S0121</b> - for boilers DC40G, DC50, C30, C40 old version - supersede 120/35 Kora	<i>Price:</i>
	<i>Weight: 2,90 kg</i>

### Radial fan – Kora



<b>Code: S0121</b> 120/35 – 120/35 – substitutes radial ventilator RATAS – for boilers DC40G, DC50, C30, C40 old versions	<i>Price:</i>
	<i>Weight: 2,90 kg</i>

<b>Code: S0122</b> 120/45 – for DC70S (DC80)	<i>Price:</i>
	<i>Weight: 2,16 kg</i>

<b>Code: S0123</b> 120/55 – for DC100	<i>Price:</i>
	<i>Weight: 2,22 kg</i>

### Suction fan UCJ4C82 – only DC75SE



Only for DC75SE, DC70GSX boilers - delivered with capacitor 2µF

<b>Code: S0136</b> detached motor for DC75SE	<i>Price:</i>
	<i>Weight: 3,28 kg</i>

<b>Code: S0138</b> motor with impeller diameter Ø 200 and a plate	<i>Price:</i>
	<i>Weight: 5,42 kg</i>

### Fan – Mezaxial



<b>Code: S0111</b> for old types of boilers - fan without capacitor	<i>Price:</i>
	<i>Weight: 0,96 kg</i>



**Impeller – small – Ø 150mm - opened**



<b>Code: S0141</b> for boilers ATMOS: DC18S, DC22S, DC25S, DC20GS, C18S, DC25GS, DC30SE, DC18SP(L), DC25SP(L), DC22GSE, DC25GSE, DC32GSE, DC22SX, DC30SX, AC25S, AC35S, GSxx,	<i>Price:</i>
	<i>Weight:</i> 0,10 kg

**Board for extraction ventilator**

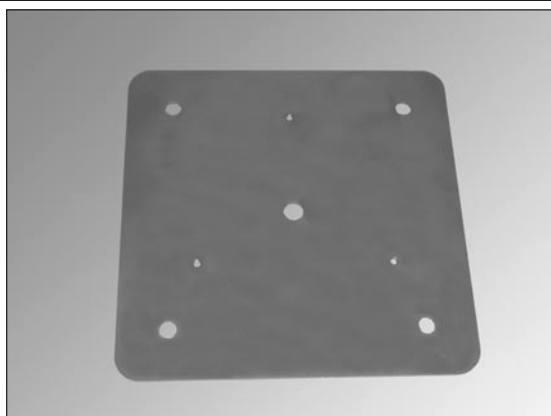

<b>Code: S0959</b> board for both types of extraction ventilator - type UCJ4C52	<i>Price:</i>
	<i>Weight:</i> 1,00 kg
<b>Code: S0961</b> board for both types of extraction ventilator - type UCJ4C82	<i>Price:</i>
	<i>Weight:</i> 1,10 kg

**Impeller – big Ø 175 mm**

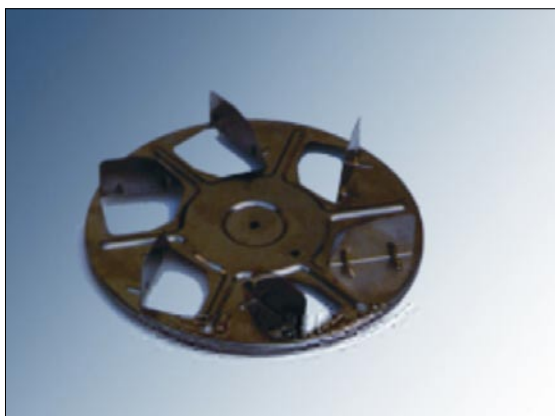

<b>Code: S0151</b> for boilers ATMOS: DC32S, DC32GS, DC40GS, DC50S, C20S, C30S, C80S, AC35S, D20P, DC32SP(L), DC40GSE, DC40SX, DC24RS, DC30RS, D20P, D30P, D45P	<i>Price:</i>
	<i>Weight:</i> 0,18 kg

**Small sealing of the suction fan**

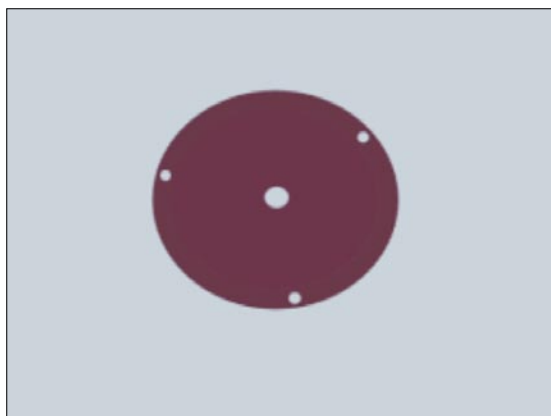

<b>Code: S0161</b> between motor and a suction fan	<i>Price:</i>
	<i>Weight:</i> 0,02 kg

**Impeller Ø 175 mm, Ø 200 mm –closed**



<b>Code: S0190</b> impeller Ø 200 mm, for DC75SE, DC70GSX	<i>Price:</i>
	<i>Weight:</i> 0,72 kg
<b>Code: S0154</b> impeller Ø 175 mm, for DC50SE, DC50S, C40S, C50S, AC45S, DC50GSE, DC50GSX, DC60GSX, D45P	<i>Price:</i>
	<i>Weight:</i> 0,38 kg

**Big sealing of the suction fan**

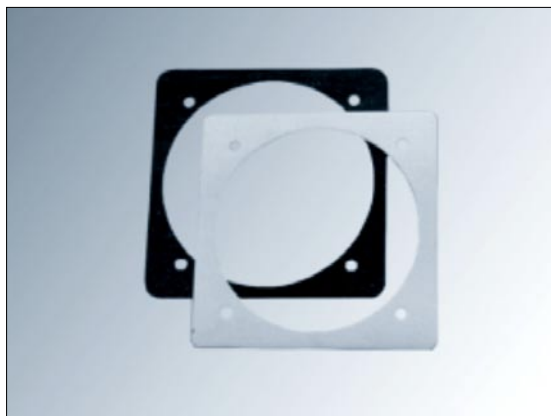

<b>Code: S0162</b> grey/red	<i>Price:</i>
	<i>Weight:</i> 0,06 kg
<b>Code: S0163</b> sibral paper – white	<i>Price:</i>
	<i>Weight:</i> 0,06 kg
<b>Code: S0167</b> grey/red for boiles DC75SE, DC70GSX	<i>Price:</i>
	<i>Weight:</i> 0,06 kg
<b>Code: S0168</b> sibral paper – white for boilers DC75SE, DC70GSX	<i>Price:</i>
	<i>Weight:</i> 0,06 kg

**Throttle branch - diameter 70 mm under regulating flap**



<b>Code: S0287</b> old version for boilers DC18S, C18S	<i>Price:</i>
	<i>Weight:</i> 0,68 kg

**Regulating flap**

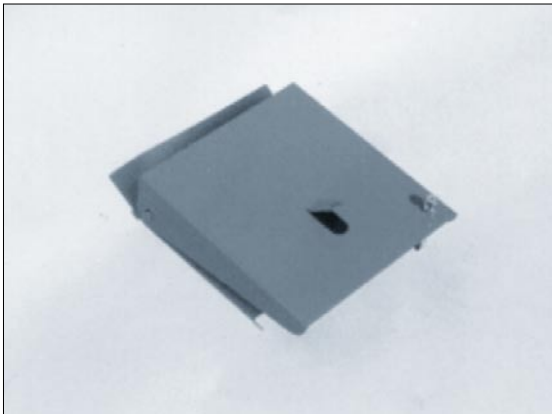

<b>Code: S0281</b> for all types of ATMOS boilers – except DC100, DC50SE (new)	<i>Price:</i>
	<i>Weight:</i> 0,32 kg

**Servocontrolled flap - GSE**

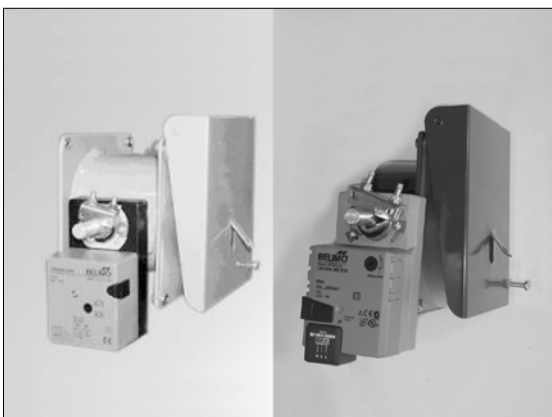

<b>Code: P0086</b> sevomotor Belimo	<i>Price:</i>
	<i>Weight:</i> 0,54 kg
<b>Code: S0257</b> mechanical flap with Shift – old type DC22GSE, DC25GSE, DC30GSE, DC40GSE, DC50GSE, DCxxGSX, GSXxx	<i>Price:</i>
	<i>Weight:</i> 2,32 kg
<b>Code: S0268</b> mechanical flap with Shift - new integrated performance DC22GSE, DC25GSE, DC30GSE, DC40GSE, DC50GSE, DCxxGSX, GSXxx	<i>Price:</i>
	<i>Weight:</i> 2,40 kg
<b>Code: S0272</b> mechanical flap with Shift - new integrated performance DC18GSE	<i>Price:</i>
	<i>Weight:</i> 2,20 kg

**FR 124 Draught regulator**



<b>Code: S0011</b> for boiler 15kW - 80kW	<i>Price:</i>
	<i>Weight:</i> 0,40 kg
<b>Code: S0012</b> Spare thermal cartridge for FR 124	<i>Price:</i>
	<i>Weight:</i> 0,04 kg

**Lid (under regulating flap)**



<b>Code: S0271</b> for all ATMOS boilers except DC70S and DC100	<i>Price:</i>
	<i>Weight:</i> 0,06 kg
<b>Code: S0956</b> for all types of ATMOS with bulit-in burner in upper door of gasification boiler - metal	<i>Price:</i>
	<i>Weight:</i> 0,32 kg

**Servocontrolled flap with spring – for DC50SE**



<b>Code: P0085</b> for DC50SE – replaces draught regulator FR124 with flap - complete	<i>Price:</i>
	<i>Weight:</i> 4,08 kg
<b>Code: P0083</b> servomotor Belimo with spring – detached	<i>Price:</i>
	<i>Weight:</i> 1,72 kg
<b>Code: S0256</b> detached mechanical flap	<i>Price:</i>
	<i>Weight:</i> 2,30 kg

**Insulation under a plate for fitting the natural gas or LFO burner to the boiler**

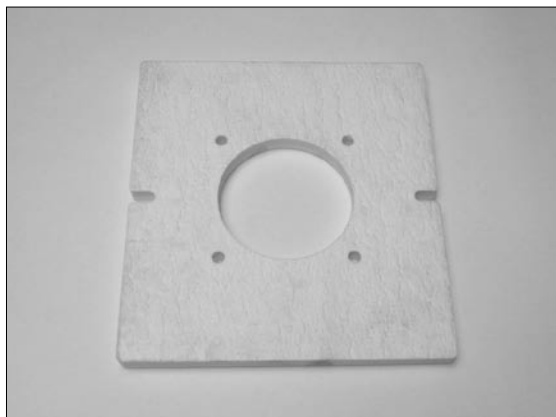

**Code: S0253** soft sibral

*Price:*

*Weight:* 0,25 kg

**Plate for fitting burner for natural gas or LFO**



**Code: S0457** for boilers DC15EP(L), DC18SP(L), DC25SP(L), DC32SP(L)

*Price:*

*Weight:* 1,40 kg

**Insulation under pellet burner for DCxxSP (EP) and for boilers with burner in upper doors**



**Code: S0164** insulation between burner and boiler – sibral – for DC15EP – DC32SP and for old model gasification boilers with burners of pellet A25 in upper doors

*Price:*

*Weight:* 0,18 kg

**Code: S0140** insulation between burner and boiler – sibral – for gasification boilers with burners of pellet A45 in upper doors

*Price:*

*Weight:* 0,10 kg

**Blind flange for blinding the hole after burner**



**Code: S0491** for boilers DC15EP(L), DC18SP(L), DC25SP(L), DC32SP(L)

*Price:*

*Weight:* 0,70 kg

**Code: S0518** for gasification boilers with burner in upper doors – thickness 4 mm

*Price:*

*Weight:* 1,64 kg

**Small door complete (with frame) – old version**



**Code: S0191** for boilers with cast iron frame screwed to the body of the boiler (with sealing cord 14 x 14mm)

*Price:*

*Weight:* 19,00 kg

**Small door complete (without frame) – new version**



Complete with handle and sleeve, with two hinges and two pins

**Code: S0201** upper right

*Price:*

*Weight:* 12,44 kg

**Code: S0202** upper left

*Price:*

*Weight:* 12,44 kg

**Code: S0203** lower right

*Price:*

*Weight:* 12,44 kg

**Code: S0204** lower left

*Price:*

*Weight:* 12,44 kg

### Large door complete (without frame)



Upper door DC100, DC75SE – new version, D14P - D31P, Pxx, DCxxGSX, GSXxx, D21

<b>Code: S0460</b> upper left	<i>Price:</i>
	<i>Weight: 14,24 kg</i>
<b>Code: S0461</b> upper right	<i>Price:</i>
	<i>Weight: 14,24 kg</i>

### Hinges complete



<b>Code: S0221</b> 2x bolt a 2x pin	<i>Price:</i>
	<i>Weight: 0,20 kg</i>
<b>Code: S0222</b> pin Ø 8x40 (8x43)	<i>Price:</i>
	<i>Weight: 0,02 kg</i>
<b>Code: S0223</b> bolt	<i>Price:</i>
	<i>Weight: 0,08 kg</i>

### Big door complete (without frame) with hole for pellet burner, LFO or natural gas

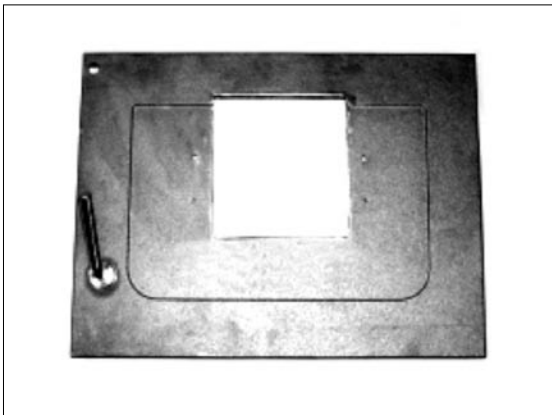

<b>Code: S0458</b> big - lower left DCxxSP(L), EP(L)	<i>Price:</i>
	<i>Weight: 14,38 kg</i>
<b>Code: S0459</b> big - lower right DCxxSP(L), EP(L)	<i>Price:</i>
	<i>Weight: 14,38 kg</i>
<b>Code: S0417</b> small – upper left for burner A25	<i>Price:</i>
	<i>Weight: 11,30 kg</i>
<b>Code: S0416</b> small – upper right for burner hořák A25	<i>Price:</i>
	<i>Weight: 11,30 kg</i>
<b>Code: S0419</b> small – upper left for burner A45	<i>Price:</i>
	<i>Weight: 11,92 kg</i>
<b>Code: S0420</b> small – upper right for burner hořák A45	<i>Price:</i>
	<i>Weight: 11,92 kg</i>

### Assembled closure (wheel, pin, puller, sleeve. nuts 2xM12)

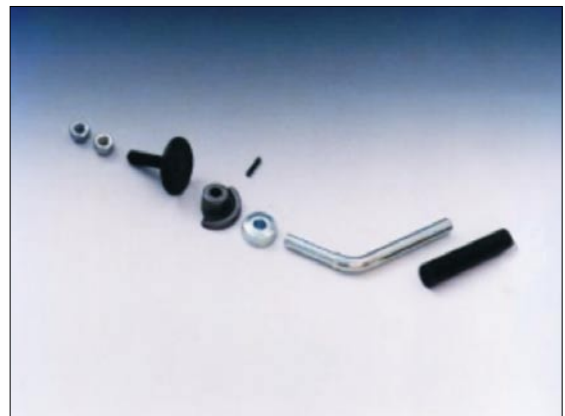

<b>Code: S0211</b> left-hand type - complete	<i>Price:</i>
	<i>Weight: 0,58 kg</i>
<b>Code: S0212</b> right-hand type – complete – default	<i>Price:</i>
	<i>Weight: 0,58 kg</i>
<b>Code: C0020</b> cam - excenter - right	<i>Price:</i>
	<i>Weight: 0,14 kg</i>
<b>Code: C0025</b> cam - excenter - left	<i>Price:</i>
	<i>Weight: 0,14 kg</i>
<b>Code: S0213</b> handle sleeve	<i>Price:</i>
	<i>Weight: 0,22 kg</i>
<b>Code: S0218</b> pin Ø 4x25	<i>Price:</i>
	<i>Weight: 0,01 kg</i>
<b>Code: S0220</b> wheel	<i>Price:</i>
	<i>Weight: 0,14 kg</i>

**Sealing cord 14x14 – for old door version**



<b>Code: S0231</b> Sealing cord for complete door with cast iron frame	<i>Price:</i>
	<i>Weight: 0,22 kg</i>

**Sealing cord 18x18 – for new door version**



<b>Code: S0241</b> for <b>small</b> door complete without frame	<i>Price:</i>
	<i>Weight: 0,40 kg</i>
<b>Code: S0240</b> for <b>big</b> door complete with cast iron frame	<i>Price:</i>
	<i>Weight: 0,40 kg</i>

**Sealing cord for burner into the boiler frame DxxP**



<b>Code: S0165</b> sealing cord 18 x 32 - into the boiler frame - D15P, D20P, D14-25P, P14-25	<i>Price:</i>
	<i>Weight: 0,38 kg</i>
<b>Code: S0174</b> sealing cord 18 x 32 - into the boiler frame - D30P, D45P, D31P, P31	<i>Price:</i>
	<i>Weight: 0,42 kg</i>
<b>Code: S0177</b> sealing cord 16 x 16 into upper door for gasification boilers with change for pellets burner	<i>Price:</i>
	<i>Weight: 0,24 kg</i>

**Side lid - new model**

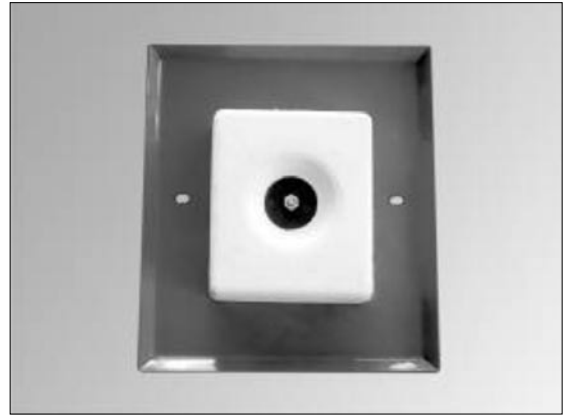

<b>Code: S0503</b> side lid - new model - when burning wood - with sibral block - for D14P - D25P, P14 - P25, DC15P, D20P from serial number 120000	<i>Price:</i>
	<i>Weight: 4,30 kg</i>
<b>Code: S0504</b> side lid - new model - when burning wood - with sibral block - for D30P, D45P, D31P, P31	<i>Price:</i>
	<i>Weight: 4,84 kg</i>
<b>Code: S0275</b> sibral block - for D14P, D21P, P14, P21, D15P, D20P, D25P, P25	<i>Price:</i>
	<i>Weight: 0,78 kg</i>
<b>Code: S0277</b> sibral block - for D30P, D45P, D31P, P31	<i>Price:</i>
	<i>Weight: 1,16 kg</i>

**Blinding lid for boilers with burner in upper door when burning wood**



<b>Code: S0525</b> complet lid for blinding the hole after burner A25	<i>Price:</i>
	<i>Weight: 3,10 kg</i>
<b>Code: S0526</b> complet lid for blinding the hole after burner A45	<i>Price:</i>
	<i>Weight: 4,30 kg</i>
<b>Code: S0278</b> sibral block for small door and burner A25	<i>Price:</i>
	<i>Weight: 0,76 kg</i>
<b>Code: S0290</b> sibral block for small door and burner A45	<i>Price:</i>
	<i>Weight: 1,30 kg</i>

**Sibral – door insulation – big - thick**

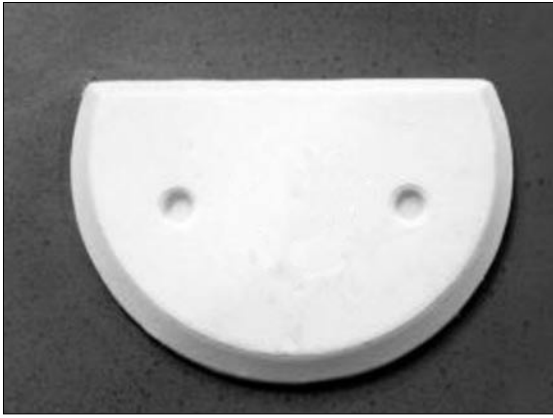

<b>Code: S0264</b> sibral for upper door without hole – DC100, DC75SE, DCxxGSX, GSXxx, D14P - D31P, Pxx, D21 + M6 x 48 + 2 washers	<i>Price:</i>
	<i>Weight:</i> 1,66 kg
<b>Code: S0263</b> detached sibral for upper door without hole thickness 42 mm – DC100, DC75SE, DCxxGSX, GSXxx, D14P - D31P, Pxx, D21	<i>Price:</i>
	<i>Weight:</i> 1,65 kg

**Sibral – door insulation – small - thick**



<b>Code: S0261</b> thickness 42 mm – as an accessories delivered with screws M6x40 and with 2 washers	<i>Price:</i>
	<i>Weight:</i> 1,48 kg
<b>Code: S0262</b> detached sibral thickness 42 mm	<i>Price:</i>
	<i>Weight:</i> 1,38 kg

**Sibral door insulation– big – thick - DCxxSPL (EPL)**



<b>Code: S0265</b> with hole prepared for LFO or natural gas burner	<i>Price:</i>
	<i>Weight:</i> 1,54 kg

**Sibral door insulation – thick with hole for pellet burner**



<b>Code: S0266</b> big – into big lower door of the boiler DCxxSP, EP	<i>Price:</i>
	<i>Weight:</i> 1,32 kg
<b>Code: S0517</b> small – into small upper doors of the gasification boiler with change for pellet burner	<i>Price:</i>
	<i>Weight:</i> 0,90 kg

**Sibral – door insulation – small - thin**



<b>Code: S0251</b> thickness 32mm – sibral delivered include screws M6x40 + 2 washers	<i>Price:</i>
	<i>Weight:</i> 1,10 kg
<b>Code: S0252</b> detached sibral thickness 32 mm	<i>Price:</i>
	<i>Weight:</i> 1,08 kg

### Lid + sealing cord



<b>Code: S0284</b> small – dimension: 105x260	<i>Price:</i>
	<i>Weight: 1,66 kg</i>
<b>Code: S0285</b> middle – dimension: 105x295	<i>Price:</i>
	<i>Weight: 1,98 kg</i>
<b>Code: S0286</b> big – dimension: 105x360	<i>Price:</i>
	<i>Weight: 2,10 kg</i>
<b>Code: S0301</b> GSE - dimension 395x205	<i>Price:</i>
	<i>Weight: 3,54 kg</i>
<b>Code: S0302</b> GSE – dimension 340x112	<i>Price:</i>
	<i>Weight: 2,06 kg</i>
<b>Code: S0507</b> GSX, DCxxR(S)	<i>Price:</i>
	<i>Weight: 3,10 kg</i>
<b>Sealing cord for:</b>	
<b>Code: S0242</b> small lid (12x12)	<i>Price:</i>
	<i>Weight: 0,08 kg</i>
<b>Code: S0243</b> middle (12x12)	<i>Price:</i>
	<i>Weight: 0,09 kg</i>
<b>Code: S0244</b> big (12x12)	<i>Price:</i>
	<i>Weight: 0,10 kg</i>
<b>Code: S0303</b> lid 340x112 GSE (12x14)	<i>Price:</i>
	<i>Weight: 0,10 kg</i>
<b>Code: S0304</b> lid 395x205 GSE (12x14)	<i>Price:</i>
	<i>Weight: 0,10 kg</i>
<b>Code: S0317</b> lid – DCxxGSX, DCxxR(S) – (12x14)	<i>Price:</i>
	<i>Weight: 0,26 kg</i>

### Lid for DxxP a D30



<b>Code: S0955</b> lid for the three-tube heat exchanger - D15P, D20P, D30P, D45P	<i>Price:</i>
	<i>Weight: 6,26 kg</i>
<b>Code: S0960</b> sealing cord for lid of heat exchanger D15P, D20P, D30P, D45P	<i>Price:</i>
	<i>Weight: 0,22 kg</i>
<b>Code: S0498</b> lid D30 - metal with sact iron ring and sealing cord	<i>Price:</i>
	<i>Weight: 4,24 kg</i>

### Firing up flap - complete

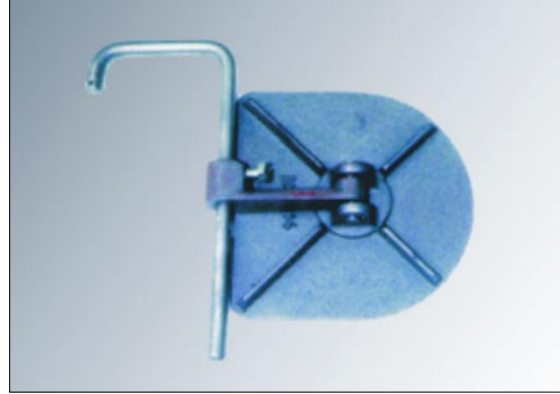

<b>Code: S0224</b> flap, shoulder, pin, nut, shaft – standard version	<i>Price:</i>
	<i>Weight: 1,64 kg</i>
<b>Code: S0232</b> flap, shoulder, pin, nut, shaft – for DC100 – with longer shaft	<i>Price:</i>
	<i>Weight: 1,70 kg</i>
<b>Code: S0229</b> milled flap, shoulder, pin, nut, shaft – DCxxGSE	<i>Price:</i>
	<i>Weight: 1,64 kg</i>

### Firing up rod

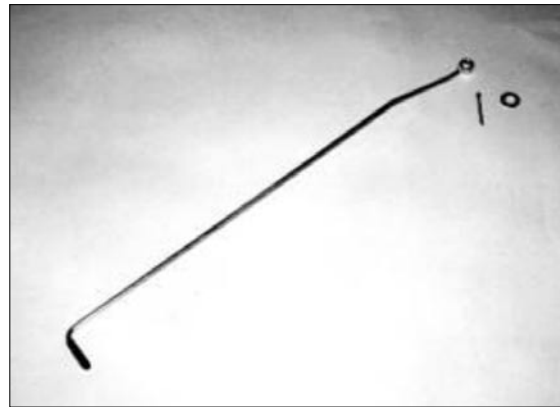
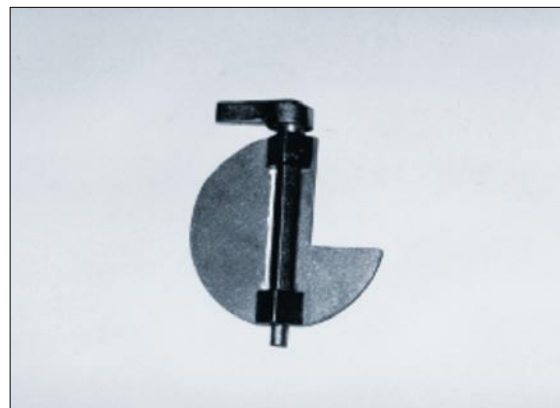

Table No. 2 on page 21	
<b>Code: S0188</b> rubber sleeve for pull rod	<i>Price:</i>
	<i>Weight: 0,01 kg</i>
<b>Code: S0784</b> washer	<i>Price:</i>
	<i>Weight: 0,01 kg</i>
<b>Code: S0761</b> split pin	<i>Price:</i>
	<i>Weight: 0,01 kg</i>

### Throttling flap into flue way Ø 152 mm



<b>Code: S0226</b> for boilers D15, D20. Able to use for decreasing of chimney draught to be installed into the flue way for DC18S - DC50SE, C18S - C40S a DC18GSE - DC50GSE, DC22SX - DC40SX, ACxxS, D30, D21, DCxxRS, DCxxGSX	<i>Price:</i>
	<i>Weight: 0,96 kg</i>

### Firing flap with a rod – air-break D30

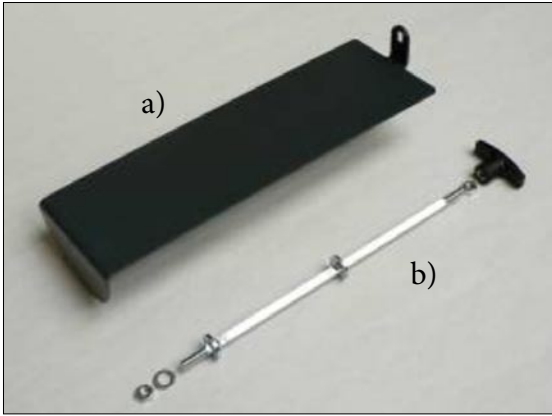

<b>Code: S0428</b> a) firing up flap without rod – air break	<i>Price:</i>
	<i>Weight: 2,70 kg</i>
<b>Code: V0512</b> b) rod	<i>Price:</i>
	<i>Weight: 0,25 kg</i>

### Instrument board label

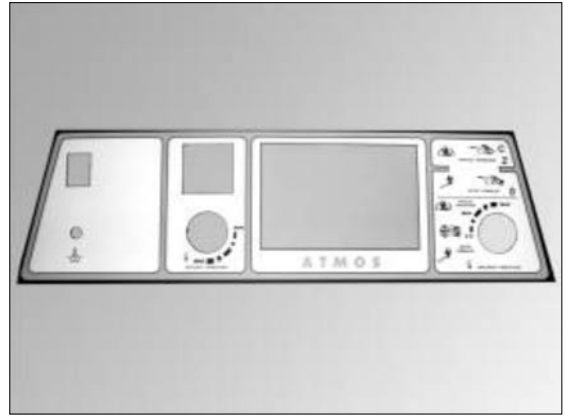

Table No. 3 on page 21

### Handle M10



<b>Code: S0279</b> for the rod of the cleaning grate for D15P, D20P, D30P, D45P, D15, D20 and for firing up flap for D30	<i>Price:</i>
	<i>Weight: 0,06 kg</i>

### Dash board – with holes for cooling loop

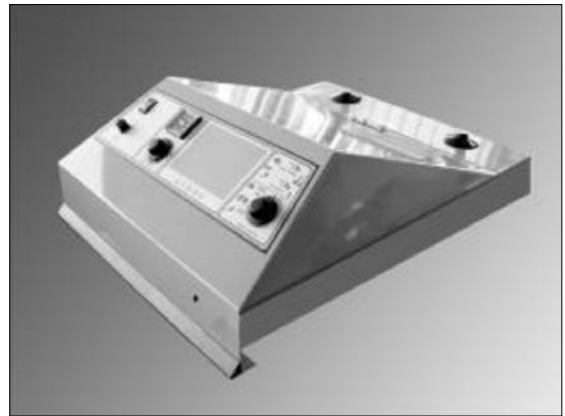

Without label and electronic  
Table No. 4 on page 22 – new version

### Nut

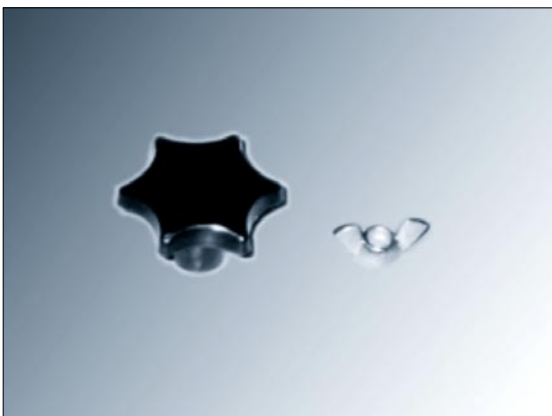

<b>Code: S0411</b> plastic nut M8	<i>Price:</i>
	<i>Weight: 0,06 kg</i>
<b>Code: S0776</b> wing nut M8	<i>Price:</i>
	<i>Weight: 0,01 kg</i>
<b>Code: S0412</b> plastic nut M12	<i>Price:</i>
	<i>Weight: 0,06 kg</i>
<b>Code: S0413</b> plastic nut M10	<i>Price:</i>
	<i>Weight: 0,06 kg</i>

### Plastic cover – round



<b>Code: S0187</b> for all boiler with cooling loop	<i>Price:</i>
	<i>Weight: 0,04 kg</i>



### Side hood



Table No. 5 on page 22 - 23

### Rear boiler hood – for D

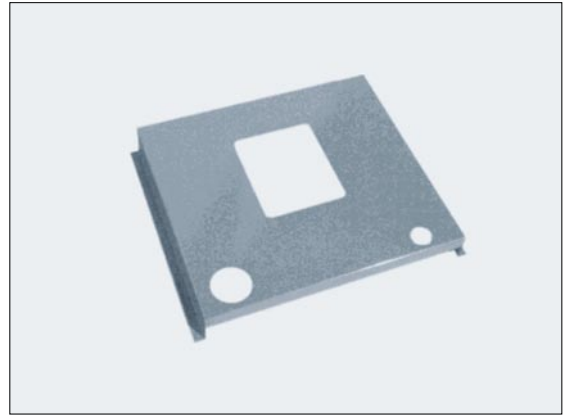

Table No. 6 on page 23

### Front boiler hood – for DC and C boilers



Table No. 6 on page 23

### Front hood for boilers DxxP

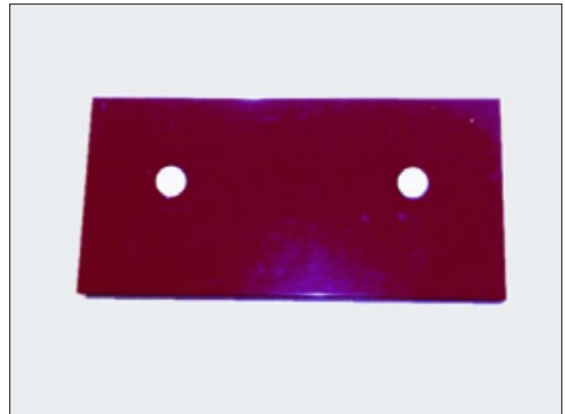

<b>Code: S0343</b> for boiler D15P – one tube type	<i>Price:</i>
	<i>Weight:</i> 1,38 kg
<b>Code: S0344</b> for boilers D15P, D20P, D30P, D45P	<i>Price:</i>
	<i>Weight:</i> 1,38 kg
<b>Code: S0497</b> upper hood of cover D30 - with hole	<i>Price:</i>
	<i>Weight:</i> 1,56 kg

### Door cover

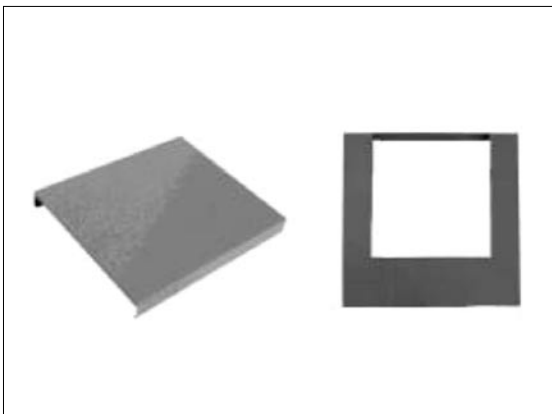

<b>Code: S0381</b> for small dor – without hole	<i>Price:</i>
	<i>Weight:</i> 1,44 kg
<b>Code: S0391</b> for big door DC100, DC75SE, DCxxGSX, GSXxx, D14P - D31P, Pxx, D21 – only upper door – without hole	<i>Price:</i>
	<i>Weight:</i> 1,62 kg
<b>Code: S0393</b> for big door with hole D15EP(L), DC18SP(L), DC25SP(L), DC32SP(L)	<i>Price:</i>
	<i>Weight:</i> 1,02 kg
<b>Code: S0415</b> pfor small door with hole for burner A25	<i>Price:</i>
	<i>Weight:</i> 0,88 kg
<b>Code: S0984</b> for small door with hole for burner A45	<i>Price:</i>
	<i>Weight:</i> 0,90 kg

### Cover of lid for tube heat exchange of the boiler DC100

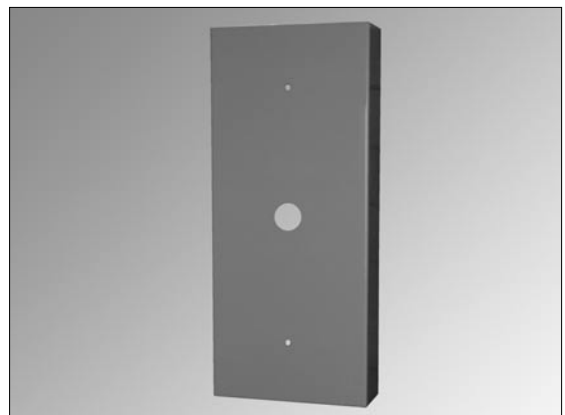

<b>Code: S0958</b> for boiler DC100 – cover of lid for tube heat exchanger	<i>Price:</i>
	<i>Weight:</i> 0,90 kg

**Front vertical hood for boiler DC100**



<b>Code: S0957</b> hood for boiler DC100 front vertical	<i>Price:</i>
	<i>Weight: 1,98 kg</i>

**Rear screen**

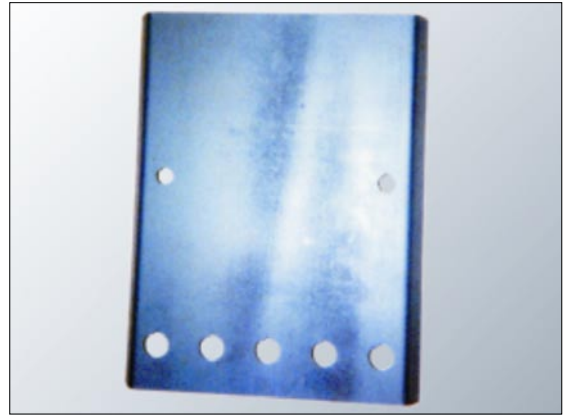

<b>Code: S0446</b> for boilers DC50SE, DC75SE	<i>Price:</i>
	<i>Weight: 2,98 kg</i>
<b>Code: S0449</b> for boilers DC40SE	<i>Price:</i>
	<i>Weight: 2,98 kg</i>

**Flue way heating insulation cover**

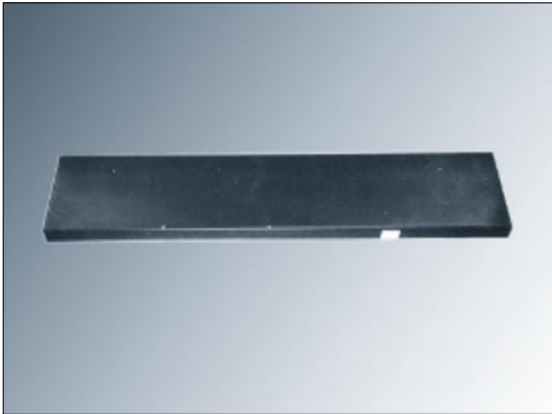
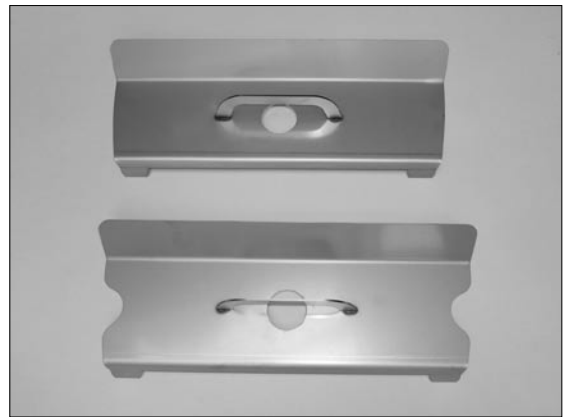

Table No. 8 on page 23

**Shield – front stainless D14P, D21P, D25P, P14, P21, P25**



<b>Code: S0937</b> for boilers D21P, D25P, P21, P25, D31P, P31	<i>Price:</i>
	<i>Weight: 0,96 kg</i>
<b>Code: S0936</b> for boilers D14P, P14	<i>Price:</i>
	<i>Weight: 0,94 kg</i>

**Frame screens**



Table No. 9 on page 24

**Lining of gasifying chamber DC50SE – 1 pc**

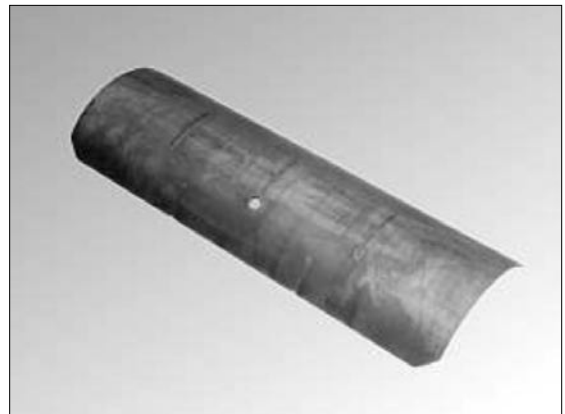

<b>Code: S0448</b> 2 pcs in 1 boiler	<i>Price:</i>
	<i>Weight: 8,28 kg</i>

### Rear flue way air-brake - 4 arm

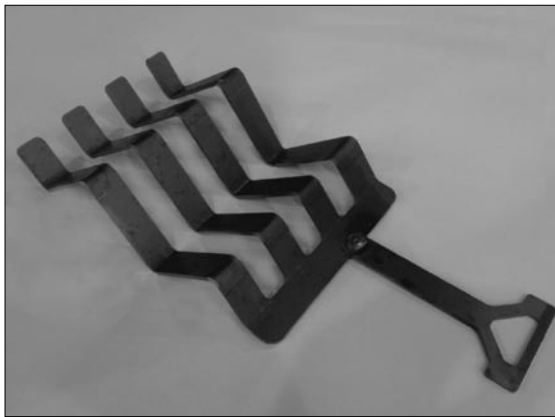

<b>Code: S0421</b> fourarm - for DC25SF, DC30SF, DC30SX, ACxxS - lenght 370 mm	<i>Price:</i>
	<i>Weight: 0,74 kg</i>

### Rear flue way air-brake - 5 arm

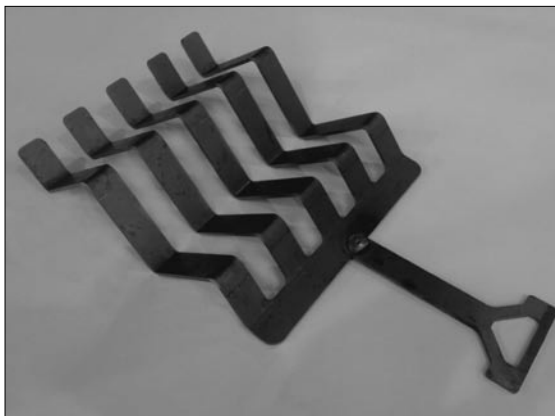

<b>Code: S0422</b> fivearm – for DC32GS, DC40GS, DC40SX, DC50S, DC70S, DC35SF, DCxxSE	<i>Price:</i>
	<i>Weight: 0,92 kg</i>

### Air-brake along the spherical chamber

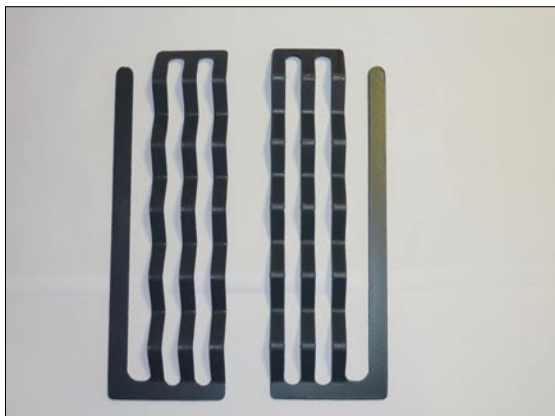

<b>Code: S0430</b> air brake – left + right (2 pcs) for DC22GSE, DC25GSE - old version	<i>Price:</i>
	<i>Weight: 1,74 kg</i>
<b>Code: S0429</b> air brake – left + right (2 pcs) for DC30GSE, DC50GSX, DC60GSX	<i>Price:</i>
	<i>Weight: 2,78 kg</i>

### Air-brake into the lower chamber - under foof

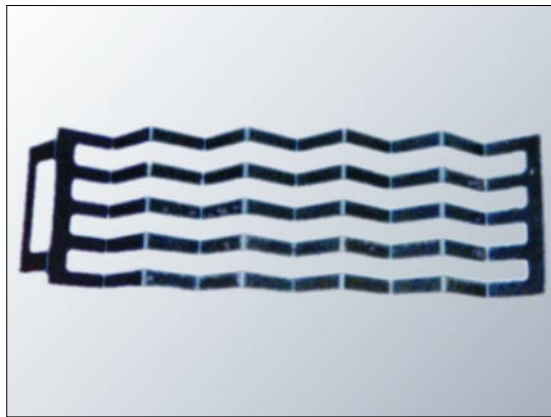

<b>Code: S0425</b> middle – lenght 600 mm for DC50SE, DC50S	<i>Price:</i>
	<i>Weight: 2,02 kg</i>
<b>Code: S0426</b> long – lenght 860 mm for DC75SE	<i>Price:</i>
	<i>Weight: 2,78 kg</i>
<b>Code: S0427</b> small – lenght 500 mm for DC40SE, DC30SX, DC40SX, DC40SE	<i>Price:</i>
	<i>Weight: 2,06 kg</i>
<b>Code: S0990</b> for DC22SX, DC25SFSX	<i>Price:</i>
	<i>Weight: 1,30 kg</i>

### Air-brake for tube heat exchanger - GSE



<b>Code: S0305</b> for boilers DC18GSE, DC22GSE, DC25GSE, DC30GSE – lenght 330 mm	<i>Price:</i>
	<i>Weight: 0,28 kg</i>
<b>Code: S0308</b> for boilers DC40GSE – lenght 430 mm	<i>Price:</i>
	<i>Weight: 0,34 kg</i>
<b>Code: S0309</b> for boilers DC50GSE – lenght 710 mm	<i>Price:</i>
	<i>Weight: 0,56 kg</i>
<b>Code: S0310</b> for boilers C50S – lenght 610 mm	<i>Price:</i>
	<i>Weight: 0,48 kg</i>

### Brush flue way air-break



<b>Code: S0423</b> air break for boiler D15P - 400 mm - old version before 31.12. 2006	<i>Price:</i>
	<i>Weight:</i> 2,68 kg
<b>Code: S0424</b> air break for boilers D20P - 400 mm - old version	<i>Price:</i>
	<i>Weight:</i> 2,90 kg
<b>Code: P0058</b> brush air break for boilers D20P - new version	<i>Price:</i>
	<i>Weight:</i> 0,24 kg
<b>Code: P0064</b> brush air break for boilers D45P - new version	<i>Price:</i>
	<i>Weight:</i> 0,48 kg
<b>Code: P0063</b> brush air break for boilers D30P - new version	<i>Price:</i>
	<i>Weight:</i> 0,40 kg
<b>Code: S0428</b> air break for boilers D30	<i>Price:</i>
	<i>Weight:</i> 2,70 kg

### Flue way air-break



<b>Code: P0098</b> for D14P, D21P, P14, P21 - 490 mm	<i>Price:</i>
	<i>Weight:</i> 0,70 kg
<b>Code: P0210</b> for D25P, D31P, P25, P31 - 590 mm	<i>Price:</i>
	<i>Weight:</i> 0,88 kg
<b>Code: P0099</b> for DCxxGSX, GSXxx - 830 mm	<i>Price:</i>
	<i>Weight:</i> 1,36 kg
<b>Code: P0087</b> for DC30RS - 596 mm	<i>Price:</i>
	<i>Weight:</i> 0,92 kg
<b>Code: P0217</b> for D30P - outer - 678 mm	<i>Price:</i>
	<i>Weight:</i> 1,05 kg
<b>Code: P0218</b> for D45P - outer - 884 mm	<i>Price:</i>
	<i>Weight:</i> 1,36 kg
<b>Code: P0084</b> for D21 - 410 mm	<i>Price:</i>
	<i>Weight:</i> 0,53 kg

### Basin 1/2"



<b>Code: S0047</b> with 4 holes inside with a spring - for all types of boilers - serves for holding the sensors or other sensing units	<i>Price:</i>
	<i>Weight:</i> 0,06 kg

### Cement



Table No. 10 on page 24

**Table No. 1 - Electrical Equipment**

Electrical Equipment for boilers	Code	Price	Weight
DC18S, DC22S, DC25S, DC32S, DC50S, DC70S, DC80, DC20GS, DC25GS, DC30SE, DC32GS, DC40GS, DC40SE, DC50SE, C18S, C20S, C30S, C40S, C50S, DC22SX, DC30SX, DC40SX, AC25S, AC35S, DC24RS-CZ, DC30RS-CZ, DC25SF, DC30SF, DC35SF, DC40SF, DC50SF, DC50GSX-CZ, DC60GSX-CZ, DC70GSX-CZ	S0664		0,64 kg
DC18GSE, DC22GSE, DC25GSE, DC30GSE, DC40GSE, DC50GSE, DC24RS – DE, DC30RS-DE, DC50GSX-DE, DC60GSX-DE, DC70GSX-DE, GSxx, GSXxx	S0660		0,82 kg
DC15E, D15, D20, D21, D30, DC14R - unified design	S0643		0,62 kg
DC100, DC100TF	S0651		1,05 kg
D20P, D30P, D31P, P31, D45P - unified design	S0645		1,02 kg
D15P, D14P, D21P, D25P, P14, P21, P25 - unified design	S0663		1,48 kg
DC15EP(L)	S0652		1,14 kg
DC18SP(L), DC25SP(L), DC32SP(L)	S0655		1,06 kg
DC75SE, DC75SF	S0649		1,08 kg

**Table No. 2 - Firing up rod**

Boiler type	Lenght	Code	Price	Weight
DC18S, C18S, DC20GS, DC15EP(L), DC18SP(L), C20S, DC18GSE, DC22GSE, DC25GSE, DC22SX, AC25S, DC15E, AC35S, DC14R, DC24RS, DC30RS	620	V0465		0,16 kg
C30S	720	V0466		0,20 kg
DC22S, DC25S, DC25GS, DC32S, DC32GS, DC40GS, DC40SE, DC30GSE, DC40GSE, DC50GSE, C40S, C50S, DC30SX, DC40SX	820	V0467		0,21 kg
DC50S, DC50SE, DC80, DC70S	1020	V0468		0,26 kg
DC75SE	1320	V0469		0,58 kg
DC 100	1045	V0474		0,46 kg

**Table No. 3 - Dash board labels**

Boiler type	Type	Code	Price	Weight
DC18S, DC22S, DC25S, DC32S, DC50S, DC70S, DC80, DC30SE, DC40SE, DC50SE, DC75SE, C18S, C20S, C30S, C40S, C50S, DC22SX, DC30SX, DC40SX, AC25S, AC35S	ČESKÁ	S0371		0,03 kg
DC20GS, DC25GS, DC32GS, DC40GS, DC50GSX-CZ, DC60GSX-CZ, DC70GSX-CZ, DC24RS, DC30RS	ČESKÁ	S0597		0,03 kg
DC100	ČESKÁ	S0373		0,03 kg
DC15E, D15, D20, D21, D30	ČESKÁ	S0372		0,03 kg
DC14R	ČESKÁ	S0524		0,03 kg
D15P, D20P, D30P, D45P, D14P, D21P, D25P, D31P	ČESKÁ	S0384		0,03 kg
D15P – old version	ČESKÁ	S0383		0,03 kg
DC18SP(L), DC25SP(L), DC32SP(L)	ČESKÁ	S0593		0,03 kg
DC15EP(L)	ČESKÁ	S0595		0,03 kg
DC18SF, DC25SF, DC30SF, DC35SF, DC40SF, DC50SF, DC70TF, DC75SF	ŠVÉDSKÁ	S0374		0,03 kg
DC100TF	ŠVÉDSKÁ	S0376		0,03 kg
DC18S, DC20GS, DC25GS, DC32GS, DC40GS, DC50SE, DC40SE, DC75SE, DC30SE, KC25S, GSxx, GSXxx	NĚMECKÁ	S0377		0,03 kg
DC18GSE-DC50GSE, DC30RS-DE, DC50GSX-DE, DC60GSX-DE, DC70GSX-DE, GSxx, GSXxx	NĚMECKÁ	S0378		0,03 kg
D15, D20, D30, DC15E	NĚMECKÁ	S0375		0,03 kg
DC14R	NĚMECKÁ	S0522		0,03 kg
D15P – old version	NĚMECKÁ	S0385		0,03 kg
D15P, D20P, D30P, D45P, P14, P21, P25, P31	NĚMECKÁ	S0386		0,03 kg
DC18SP(L), DC25SP(L), DC32SP(L)	NĚMECKÁ	S0594		0,03 kg
DC15EP(L)	NĚMECKÁ	S0596		0,03 kg
DC18S, DC20GS, DC25GS, DC32GS, DC40GS, DC40SE, DC50SE, DC75SE, DC30SE,	SIEGER	S0387		0,03 kg
FBV22-FBV50	SIEGER	S0523		0,03 kg
DC15E	SIEGER	S0388		0,03 kg
D15P, D20P, D30P, D45P	SIEGER	S0390		0,03 kg

## ATTENTION – specify color in the order

**Table No. 4 - Dash board – with holes for cooling loop**

Boiler type	Wide	Deepness	Code	Price	Weight
DC18S, DC25SF, D15, C18S, C20S, DC22SX, AC25S, DC15, AC35S, KC25S, KC35S	540	480	S0311		4,20 kg
DC20GS, DC18GSE, DC22GSE, DC14R, DC24RS, DC30RS, GS20, DC25GSE - old version	540	480	S0299		4,08 kg
DC35SF, DC40SF, DC40SE, DC30SE, C40S, DC22S, DC25S, DC32S, DC30SX, DC40SX, D20, D21, D30	540	680	S0312		5,32 kg
DC25GS, DC32GS, DC40GS, DC30GSE, DC40GSE, DC50GSE, GS25 - GS40, GSXxx, DC25GSE - since 15.4.2012	504	680	S0306		5,32 kg
DC50GSX, DC60GSX, DC70GSX	504	680	S0369		5,30 kg
C30S, AC45S, KC45S	540	580	S0462		5,00 kg
DC50SE, DC50SF, DC50S, DC80, DC70S	540	880	S0313		7,00 kg
DC75SE	540	118	S0314		7,40 kg
D15P, D20P	540	480	S0296		4,08 kg
DC100	915	900	S0439		10,48 kg
DC15EP(L), DC18SP(L)	540	480	S0463		4,20 kg
DC25SP(L)	540	680	S0464		5,32 kg
DC32SP(L)	540	680	S0465		5,32 kg
D30P	540	680	S0315		5,32 kg
D45P	540	880	S0316		7,00 kg
D14P, D21P, P14, P21 - without cooling loop	540	559	S0318		3,90 kg
D25P, P25, D31P, P31 - without cooling loop	540	680	S0368		5,26 kg

**Table No. 5 - Side hood**

Boiler type	High	Deepness	Code		Price	Weight
			Left side	Right side		
DC15E, C18S, D15, DC18S, DC22SX, AC25S	925	485	S0321	S0322		4,52 kg
D20, D21, DC22S, DC25S, DC30SX	925	685	S0323	S0324		6,10 kg
DC32S, DC40SX, DC30SE	1020	675	S0325	S0326		7,70 kg
DC25GS, DC32GS, DC30GSE, DC25GSE od 15.4.2012	1120	685	S0561	S0562		8,10 kg
DC25GSE - old version	1225	485	S0563	S0564		8,25 kg
DC20GS, DC18GSE, DC22GSE DC24RS, DC30RS	1120	485	S0565	S0566		10,05 kg
DC40GS, DC40GSE, DC50GSE	1225	685	S0567	S0568		9,20 kg
DC50GSX, DC60GSX	1360	685	S0575	S0576		9,70 kg
DC70GSX	1460	685	S0569	S0570		9,80 kg
DC50S, DC70S (80)	1015	870	S0331	S0332		7,60 kg
DC100	1250	900	S0333	S0334		10,36 kg
DC40SE	1125	670	S0364	S0365		8,95 kg
DC50SE	1125	870	S0335	S0336		9,30 kg
C20S, AC35S, KC35S	1117	482	S0337	S0338		5,58 kg
C30S, AC45S, KC45S	1117	582	S0339	S0340		6,10 kg
C40S, D30	1117	682	S0341	S0342		7,86 kg
DC75SE – front	1230	585	S0347	S0348		9,58 kg
DC75SE – rear	1230	585	S0349	S0350		9,58 kg
D20P, D15P – with hole – without coffin	1117	485	S0394	S0395		5,36 kg
D20P, D15P – without hole – without coffin	1117	485	S0396	S0397		5,58 kg
DC18SP(L), DC15EP(L)	1240	485	S0476	S0477		6,70 kg
DC25SP(L)	1240	685	S0478	S0479		7,20 kg
DC32SP(L)	1240	675	S0494	S0495		6,90 kg
D30P – with hole	1117	685	S0606	S0605		6,56 kg

D45P – with hole	1117	885	S0608	S0607		7,10 kg
DC14R	1035	485	S0585	S0586		7,50 kg
KC25S	925	485	S0587	S0588		7,16 kg
D14P, D21P, P14, P21	958	583	S0589	S0590		5,84 kg
D25P, P25	958	683	S0621	S0622		6,70 kg

**Table No. 6 - Front side DC and C boilers**

Boiler type	Wide	High	Popis	Code	Price	Weight
DC15E, DC18S, DC22S, DC25S, DC22SX, DC30SX, DC15E-P(L), DC25SP(L), DC18SP(L)	575	190		S0351		1,26 kg
C18S, AC25S	575	190	s dírou	S0352		1,24 kg
DC32S, DC20GS, DC25GS, DC32GS, DC50S - staré provedení, DC18GSE, DC22GSE, DC30GSE, DC40SX, GS20, GS25, GS32, DC25GSE - since 15.4.2012	655	265		S0353		1,86 kg
DC50S - nové provedení od 2012	575	190	s dírou	S0581		1,66 kg
DC14R	655	265	s dírou	S0582		1,80 kg
DC24RS, DC30RS	655	470		S0583		2,96 kg
DC50GSX, DC60GSX, GSX50, GSX60				S0584		3,10 kg
DC70GSX, GSX70	655	265		S0466		1,82 kg
DC32SP(L) - vrchní	575	440	s dírou	S0354		2,76 kg
C20S, C30S, C40S, AC35S	665	425		S0355		2,78 kg
DC40GS, GS40, DC70S(80), DC40GSE, DC25GSE - old version	665	425	s dírou	S0367		2,76 kg
DC40SE, DC50SE	665	375		S0356		3,64 kg
DC100	620	520		S0357		3,62 kg
D15P, D20P, D15, D20, D30, D30P, D45P	585	380		S0358		1,90 kg
DC75SE	654	435		S0359		2,88 kg
DC15EP(L), DC18SP(L), DC25SP(L) - bottom	575	68		S0409		0,84 kg
DC32SP(L) - bottom	575	68		S0403		0,84 kg
D14P, D21P, D25P, P14, P21, P25	522	308		S0512		2,00 kg
D31P	522	408		S0363		2,50 kg
D21	522	343		S0370		2,05 kg

**Table No. 7 - Rear hood for D**

Boiler type	Wide	High	Code	Price	Weight
D15, D20	565	550	S0361		3,00 kg
D15P, D20P, D30P, D45P	585	470	S0362		2,46 kg
D30	585	470	S0360		2,60 kg
D14P, D21P, D25P, P14, P21, P25	542	510	S0513		3,00 kg
D21	740	533	S0398		2,50 kg

**Table No. 8 - Flue way heating insulation cover**

Boiler type	length x wide	Code	Price	Weight
DC15E, DC24RS, DC14R	790 x 145	S0410		1,32 kg
DC30RS	840 x 197	S0571		1,78 kg
DC18S, DC22S, DC25S, C18S, AC25S, DC22SX, DC30SX	790 x 175	S0431		1,56 kg
DC32S, DC25GS, DC20GS, DC32GS, DC30SE, DC22GSE, DC30GSE, DC40SX	880 x 175	S0432		1,74 kg
DC40GS, C20S, C30S, C40S, DC25GSE, AC35S	1030 x 175	S0433		2,00 kg
DC40GSE, DC50GSE	880 x 240	S0440		2,58 kg
DC50GSX, DC60GSX	1130 x 197	S0572		2,40 kg
DC50SE, DC40SE	975 x 175	S0434		2,23 kg
DC75SE	1075 x 175	S0435		2,32 kg
DC70GSX	x	S0573		1,72 kg

DC15EP(L), DC18SP(L), DC25SP(L) – front left	1437 x 142	S0404		2,78 kg
DC15EP(L), DC18SP(L), DC25SP(L) – front right	790 x 142	S0405		1,56 kg
DC32SP(L) – front left	1527 x 142	S0406		2,96 kg
DC32SP(L) – front right	895 x 142	S0407		1,70 kg

**Table No. 9 - Frame screens**

Boiler type	Description	Code	Price	Weight
DC18S, DC15E, DC22S, DC25S, DC32S, DC20GS, DC25GS, DC32GS, DC40GS, DC70S, DC80, DC15EP(L) – DC32SP(L), DC22SX – DC40SX, AC(KC)35S, AC(KC)45S, DC18GSE – DC50GSE, DC24RS, DC30RS	High-level screen – L	S0441		1,74 kg
DC50SE	High-level thin screen – L With two noseies	S0442		3,90 kg
DC75SE, DC40SE	Low-level screen – L With two noseies – similar to DC50SE screen	S0445		3,90 kg
C18S, KC25S, AC25S	High-level halfround – L screen from a special material	S0443		1,28 kg
C20S, C30S, C40S, C50S	High-level screen – profiled from a special material	S0444		2,84 kg
DC100, DC50GSX, DC60GSX, DC70GSX	L - screen	S0447		3,98 kg
D15, D20, D30, D15P, D20P, D30P, D45P	Screen with holes	S0450		1,44 kg
D21	Screen with holes	S0502		1,50 kg

**Table No. 10 - Cement**

Typ	Code	Price	Weight
Boiler cement (Rudokit) – 1package (middle bag) – approx. 0,5 kg – used for sealing ceramic blocks by all ATMOS Combi CxxS boilers and for sealing the ceramic nozzles at the Atmos Generators DCxxGS boilers between nozzle and wall of the boiler	S0451		0,50 kg
Boiler cement (Rudokit) – one package 10 kg – for boiler CxxS Combi	V0341		10,00 kg
Boiler cement - white - 1 package (big bag) - approx 1 kg – used for sealing the ceramic nozzle for all gasification boilers ATMOS	S0452		1,00 kg
Boiler cement - white – full package 15 kg for boilers DCxxS ( GS, GSX,GSE,SX )	V0321		15,00 kg
Boiler cement in a tube – - Sticking to the sealing cord on the sides of the filling area for the type DCxxGS, DCxxGSE, GSxx - 1 pack	V0345		0,66 kg



## 2. Wood gasification DCxxS, GS, wood burning Dxx, pellet DxxP or natural gas or LFO boilers typ EP(L), SP(L)



**A) Spherical chamber 5-pcs– Left + Right**



<b>Code: DC0011</b> spherical chamber L+R side - the oldest version for boiler types DC25G, DC32G, DC40G, manufacture year 1992-96, for boilers with cast iron frame in the door (twoparts left + twoparts right side + ceramic half moon)	<i>Price:</i>
	<i>Weight: 37,00 kg</i>

**Spherical chamber 3-pcs– L+R**

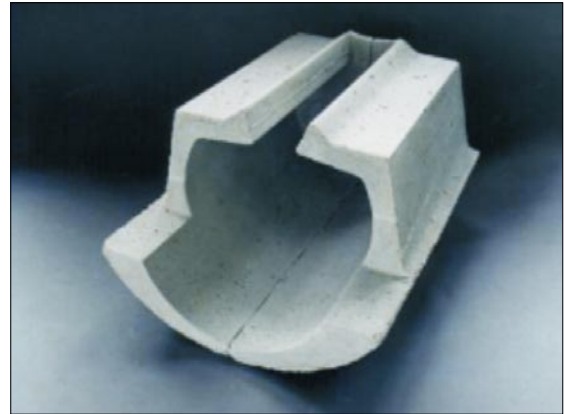

<b>Code: DC0061</b> old version for boiler types DC25G(S), DC32G(S), DC40G(S) – left + right side	<i>Price:</i>
	<i>Weight: 34,44 kg</i>
<b>Code: DC0062</b> old version for boilers DC18 – smaller form (L+R sides can be used in older boilers DC18 with ceramic roof)	<i>Price:</i>
	<i>Weight: 19,60 kg</i>

**B) Prolonging of the spherical chamber 5-pcs L+R**



<b>Code: DC0012</b> front ceramic parts of the chamber, right and left are the same	<i>Price:</i>
	<i>Weight: 4,30 kg</i>

**Ceramic block**



<b>Code: DC0031</b> ceramic block for boilers DC50S, DC50SE, DC70S, DC80, DC50GSX, DC60GSX, DC70GSX	<i>Price:</i>
	<i>Weight: 8,90 kg</i>

**Ceramic door screen - half moon**



<b>Code: DC0021</b> for all types of boilers ATMOS Generators – GS, GSE, GSX, DC18S, DC100 For all types of boilers ATMOS Combi, DC18SP(L), ACxxS, DCxxR(S)	<i>Price:</i>
	<i>Weight:</i> 4,50 kg

**Combustion chamber lining DC15E (DC18S), DC15EP(L)**

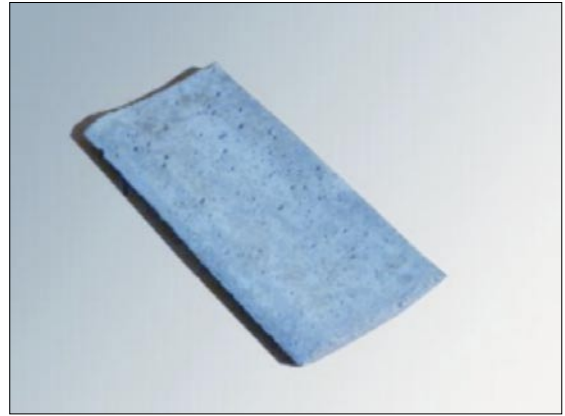

<b>Code: DC0141</b> 2 pcs for one boiler	<i>Price:</i>
	<i>Weight:</i> 6,22 kg

**Ceramic triangle part**



<b>Code: DC0051</b> old version for boilers: DC25S, DC32S (DC25, DC32) triangle with marks (2)	<i>Price:</i>
	<i>Weight:</i> 1,14 kg

<b>Code: DC0052</b> old version for boilers: DC50S (DC50). Old version – DC32 (the frame of the lower door is not made of one pieces of sheet plate) - triangle with marks (1).	<i>Price:</i>
	<i>Weight:</i> 1,22 kg

**Half moon ceramic shaped part – DCxxG**



<b>Code: DC0071</b> for types DC25G(S), DC32G(S), DC40G(S) – old version (dimensionally bigger then for DC18(S))	<i>Price:</i>
	<i>Weight:</i> 1,24 kg

**Half moon ceramic shaped part – DC18**



<b>Code: DC0101</b> for types DC18(S) – old version	<i>Price:</i>
	<i>Weight:</i> 1,58 kg

**Half moon ceramic part – into DC70S**



<b>Code: DC0111</b> half moon DC70S, DC80	<i>Price:</i>
	<i>Weight:</i> 2,44 kg

**A) 4-piece spherical chamber L+R**



Table No. 11 on page 30

**Combustion chamber side – for boilers GS**

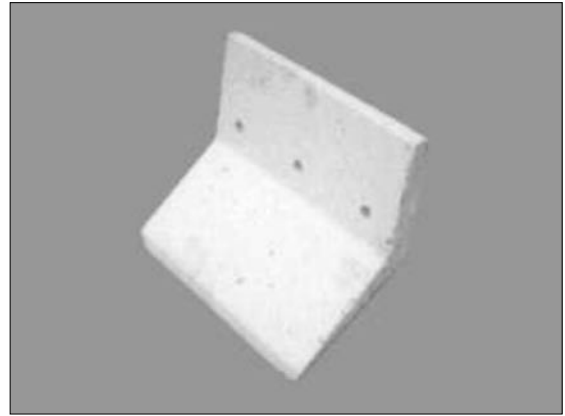

Table No. 14 on page 31

**B) Rear portion of 4-piece spherical chamber**



<b>Code: DC0091</b> rear portion for boilers: C18S, DC18S, DC20GS, DC25GS, DC32GS, DC40GS, (DC50S), DC30SE, DC18SP(L), DC18GSE - DC50GSE, AC25S, DCxxR(S), KC25S, DCxxGSX	<i>Price:</i>
	<i>Weight:</i> 7,48 kg

**Ceramic roof**



<b>Code: DC0042</b> new version for boilers: DC18S, DC18SP(L) lenght – 320 mm	<i>Price:</i>
	<i>Weight:</i> 8,22 kg
<b>Code: DC0043</b> new version for boilers: DC22S, DC25S, DC30SE, DC40SE, (DC75SE-(2ks)), DC32S, DC25SP(L), DC32SP(L), DC22SX – DC40SX – lenght = 500 mm	<i>Price:</i>
	<i>Weight:</i> 12,08 kg
<b>Code: DC0044</b> new version for boilers: DC50S, DC50SE, (DC50) - lenght = 700 mm	<i>Price:</i>
	<i>Weight:</i> 16,62 kg

**Sibral strip (2pcs for boiler)**



<b>Code: S0453</b> for sealing gap between ceramic spherical parts and nozzle holder – for boilers DC18S, DC20GS, DC25GS, DC32GS, DC40GS, DC18SP(L) DC30SE, DCxxGSE, DCxxGSX, DC22SX	<i>Price:</i>
	<i>Weight:</i> 0,10 kg

**Nozzle**



Table No. 13 on page 31

The nozzle is supplied always with boiler cement and with along laid sealing cords (3 pcs of sealing cords)

### Combustion chamber board for DC80 and DC70S

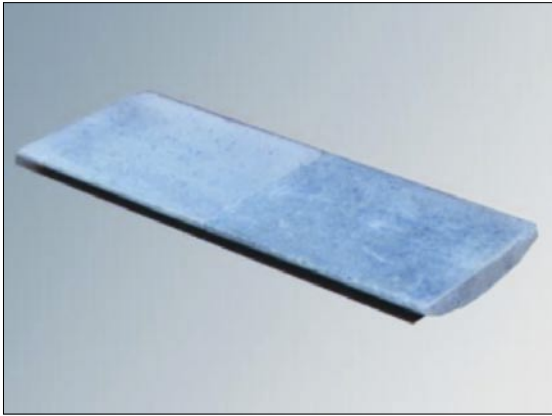

**Code: DC0151** consists of 2 pcs

*Price:*

*Weight:* 10,90 kg

### Combustion chamber dome (arch)

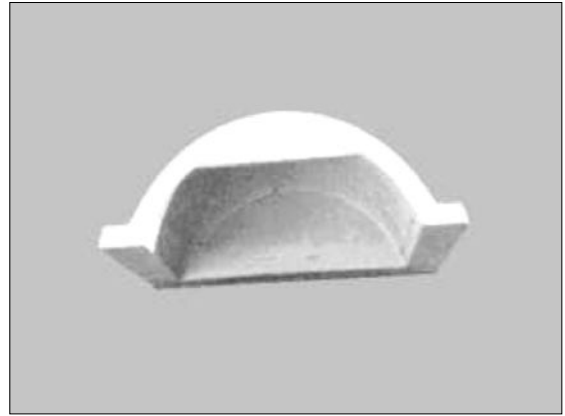

**Code: D0011** small – for boilers DC15E, DC15EP(L), D15, D15P, D20P

*Price:*

*Weight:* 10,96 kg

**Code: D0015** big – for boilers DC25SPL, DC32SPL, D20, D30, D30P

*Price:*

*Weight:* 17,28 kg

**Code: D0045** small with prolonging for boilers D45P (D0011+D0044)

*Price:*

*Weight:* 30,14 kg

### Combustion chamber sid DCxxGSX

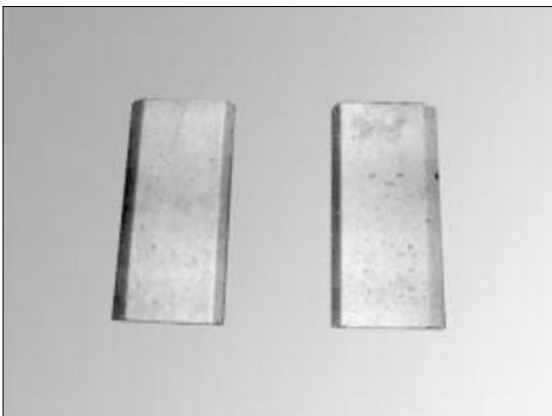

**Code: DC0183** for DC50GSX, DC60GSX, DC70GSX – (consists of 4 pcs DC0181)

*Price:*

*Weight:* 10,60 kg

### Rear board of the combustion chamber



**Code: D0021** for boilers D15, D15P, D20P, D20, D30, D30P, D45P

*Price:*

*Weight:* 10,98 kg

### Bottom part of combustion chamber DC15E, DC15EP(L)

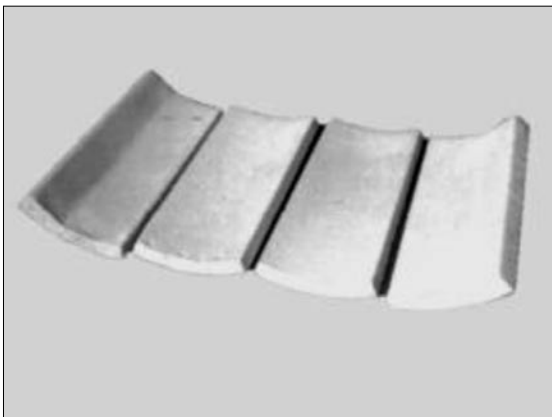

Consists – 2 ks - outer part A; 2 ks – middle part B

**Code: DC0118** outer part – 2 pcs

*Price:*

*Weight:* 7,90 kg

**Code: DC0115** middle part – 2 pcs

*Price:*

*Weight:* 8,30 kg

**Code: DC0184** complet (DC0118 + DC0115) - 4pcs

*Price:*

*Weight:* 16,20 kg

### Bottom of the combustion chamber – old version



**Code: D0031** for pellet boilers D15P, D20P and for D15, D20 - consists of two pieces – old version of boilers (2x D0032)

*Price:*

*Weight:* 6,50 kg

**Bottom of the combustion chamber D15, D20, D30, D30P - new version**

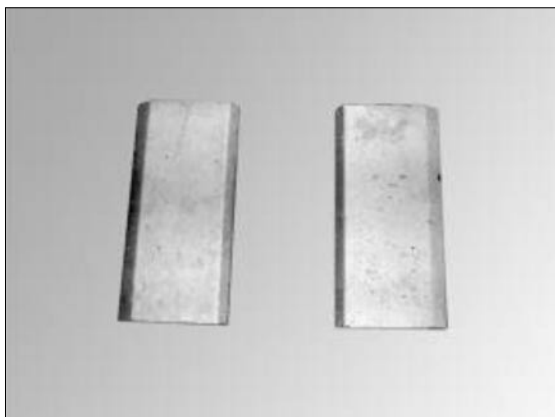

<b>Code: D0039</b> for boilers D15 – consists of two pieces – new version (2x D0034)	<i>Price:</i>
	<i>Weight: 6,10 kg</i>
<b>Code: D0038</b> for boilers D20, D30, D30P D21 – consists of four pieces – new version (4x D0037)	<i>Price:</i>
	<i>Weight: 10,30 kg</i>

**Bottom of the combustion chamber D15P, D20P - new**

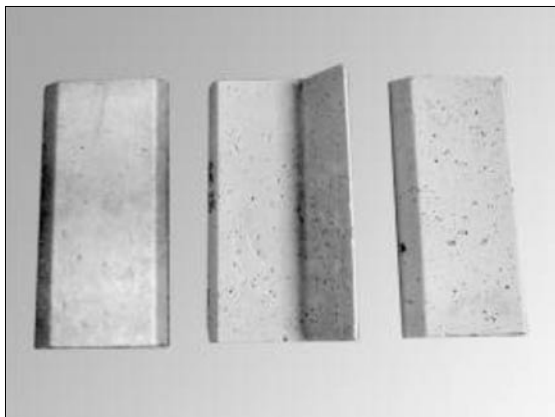

<b>Code: D0034</b> for boilers D15P, D20P – side part without channel for side plate	<i>Price:</i>
	<i>Weight: 5,60 kg</i>
<b>Code: D0035</b> for boilers D15P, D20P – side part with a channel for side plate	<i>Price:</i>
	<i>Weight: 3,80 kg</i>
<b>Code: D0036</b> side plate of burning chamber is to be put on side part with channel D0035	<i>Price:</i>
	<i>Weight: 5,20 kg</i>
<b>Code: D0043</b> for boilers D45P – side part without channel for side plate (2 pcs.)	<i>Price:</i>
	<i>Weight: 3,38 kg</i>
<b>Code: D0046</b> for boilers D45P – side part with a channel for side plate (2 pcs.)	<i>Price:</i>
	<i>Weight: 4,76 kg</i>
<b>Code: D0047</b> side plate of the burning chamber for D30P, D45P to be put on side part with channel D0046	<i>Price:</i>
	<i>Weight: 5,90 kg</i>
<b>Code: D0042</b> for boilers D30P – side part without channel for side plate (2 pcs.)	<i>Price:</i>
	<i>Weight: 4,80 kg</i>
<b>Code: D0037</b> for boilers D30P – side part with a channel for side plate (2 pcs.)	<i>Price:</i>
	<i>Weight: 2,24 kg</i>

**Parts for grating for D15P, D20P, D15, D30P, D45P**

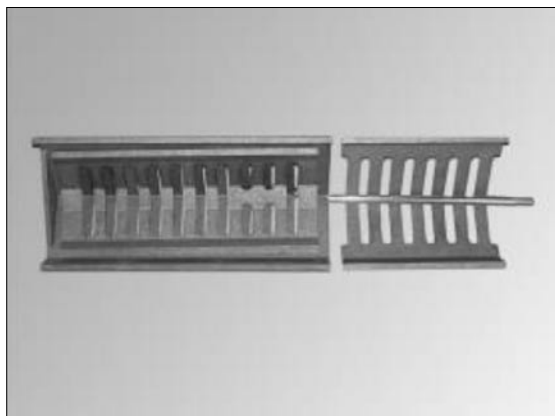

<b>Code: C0006</b> lower grate – stationary for boilers D15, D15P, D20P	<i>Price:</i>
	<i>Weight: 3,12 kg</i>
<b>Code: C0007</b> upper grate – moveable for boilers D15, D15P, D20P	<i>Price:</i>
	<i>Weight: 1,80 kg</i>
<b>Code: C0003</b> grate complet – for boilers D15, D15P, D20P – consists of (1x C0006 + 1x C0007)	<i>Price:</i>
	<i>Weight: 5,00 kg</i>
<b>Code: V0654</b> prolonging of the lower grate – stationary – for boilers D30P, D45P	<i>Price:</i>
	<i>Weight: 1,54 kg</i>
<b>Code: C0005</b> grate complet – for boilers D20, D21, D30, D30P - consists of (1x C0006, C0007 and 1x V0654)	<i>Price:</i>
	<i>Weight: 6,54 kg</i>
<b>Code: C0004</b> grate complet - for biler D45P – consists of (1x C0006, C0007 and 1x V0654)	<i>Price:</i>
	<i>Weight: 8,10 kg</i>
<b>Code: V0510</b> tow bar D15, D15P, D20P	<i>Price:</i>
	<i>Weight: 0,12 kg</i>
<b>Code: V0511</b> tow bar D20, D30, D30P	<i>Price:</i>
	<i>Weight: 0,26 kg</i>
<b>Code: V0513</b> tow bar D45P	<i>Price:</i>
	<i>Weight: 0,38 kg</i>
<b>Code: V0527</b> tow bar D21	<i>Price:</i>
	<i>Weight: 0,28 kg</i>

**Table No. 11 - 4-piece spherical chamber L+R**

Boiler type	Depth of spherical chamber	Code spherical chamber complete – left + right side + rear face	Price	Weight	Code spherical chamber only left + right side	Price	Weight
DC18S, DC20GS, DC18SP(L), DC18GSE, DC22GSE, GS20, DC25GSE - old version	310	DC0081		23,14	DC0085		16,42 kg
DC25GS, DC30GSE, DC50GSX, GS25, GSX50	510	DC0082		43,70	DC0086		36,64 kg
DC32GS, DC30SE, DC60GSX, GS32, GSX60	510	DC0082		43,70	DC0086		36,64 kg
DC40GS, DC40GSE, DC50GSE, GS40	510	DC0082		43,70	DC0086		36,64 kg
DC50SE – old version	510 + 200	DC0087		56,92	DC0088		49,88 kg
Prolonging of the spherical chamber for DC50SE (DC50S) – 200 mm – old version					DC0089		13,22 kg
Fo□ ATMOS Combi ceramic parts but lower and with nose)							
<b>NOTICE – the spherical chamber for boiler DC100 is shown on pages 32, 33.</b>							

**Table No. 12 - Types and number of sealing cords for sealing ceramics – depend on boiler type**

Boiler type	Name	Pcs	Dimension	Code	Price	Weight
AC25S, AC35S, DC14R, DC24RS, DC30RS, C18S, C20S, C30S, C40S, C50S	Insulating cord - furnace grate pipe	1 1	18x18x275 22x22x275	S0940		0,16 kg
D15, D20, D21, D30, D15P, D20P, D30P, D45P	Insulating cord - combustion chamber	2 2 2	14x14x280 18x18x280 8x8x190	S0941		0,38 kg
DC15E, DC15EP(L)	Insulating cord - Nozzle	2 1 2	12x14x385 12x14x190 12x12x190	S0942		0,37 kg
DC18S	Insulating cord - Nozzle	2 1	12x14x385 12x14x190	S0943		0,29 kg
DC22S, DC25S, DC32S, DC25SP(L), DC32SP(L)	Insulating cord - Nozzle	2 1	12x14x590 12x14x190	S0944		0,28 kg
DC50S	Insulating cord - Nozzle	2 2 1 1	12x14x590 18x18x190 12x14x190 10x10x190	S0945		0,39 kg
DC70S	Insulating cord - Nozzle	2 3 1	12x14x590 18x18x190 12x14x190	S0946		0,42 kg
DC40SE	Insulating cord - Nozzle	2 1	12x14x590 12x14x190	S0947		0,26 kg
DC75SE	Insulating cord - Nozzle	2 2	14x14x1090 14x14x190	S0948		0,38 kg
DC100	Insulating cord - Nozzle	2 1 1	14x14x780 18x18x190 22x22x190	S0949		0,40 kg
DC20GS, DC18GSE, DC22GSE, GS20	Insulating cord - combustion chamber	2 2 2 1	12x14x385 12x12x385 10x10x285 12x14x190	S0950		0,37 kg
DC25GS, DC32GS, DC30GSE, GS25, GS32, DC25GSE - 15.4.2012	Insulating cord - combustion chamber	2 2 2 1	12x14x590 12x12x590 10x10x285 12x14x190	S0951		0,42 kg
DC25GSE - old version	Insulating cord - combustion chamber	2 2 1 2	12x14x385 18x18x385 10x10x190 10x10x430	S0952		0,40 kg
DC40GS, DC40GSE, DC50GSE, GS40	Insulating cord - combustion chamber	4 2 1	12x14x590 10x10x430 12x14x190	S0953		0,45 kg
DC50GSX, DC60GSX, GS50, GS60	Insulating cord - Nozzle	2 3	12x14x590 12x14x190	S0954		0,51 kg

**Table No. 13 - Ceramic nozzle**

Boiler type	A	B	C	D	E	F	Mark	Code	Price	Weight	
DC15E, DC15EP(L)			390	185				DC0120		11,80 kg	
DC18S, DC20GS, DC22SX, DC22GSE, GS20, DC25GSE - old version	140	34	390	185	110	175		DC0121		12,60 kg	
DC18	180	35 (34)	390	185	80	230		DC0122		12,10 kg	
DC22(S), DC25(S), DC30SX, DC30SF, DC25SP(L)	200	34	590	185	90	260	△	DC0125		16,60 kg	
DC25G, DC25GS, DC30SE, DC30GSE, GS25	200	34	590	185	90	260	△	DC0125		16,60 kg	
DC32G(S), DC32(S), DC32SP(L), DC40SX, GS32	240	34	590	195	110	285	○○○	DC0131		17,00 kg	
DC35 Swedish (DC40G)	240	34	590	195	110	285	○○○	DC0131		17,00 kg	
DC40GS, DC40G, DC40GSE, DC50GSE, DC50GSX, GS40, GSX50	285	34	590	195	100	315	○○	DC0132		16,90 kg	
DC25GSE since 15.4.2012	140	34	590	185	110	175	○	DC0126		16,90 kg	
DC40SE, DC60GSX, GSX60, DC70GSX, GSX70 DC50S for boilers from 1.1.2010	280	40	588	200	116	312	□□□	DC0140		17,80 kg	
DC100 – complet	230 + 280	38	392x2	200	85	61		DC0135		21,20 kg	
Cube DC50S, DC80, DC70S, DC50SE			200	200				DC0031		8,90 kg	
Nozzle DC50, DC50S for boilers till 31.12.2009	300	35	590 +cube	200			□	DC0133		17,90 kg	
Nozzle DC80, DC70S	310	35	590 +cube	200	90	370	□	DC0134		17,20 kg	
Nozzle DC50SE, DC75SE	300	50	582	200	90	332	△□	DC0130		16,30 kg	
Cube DC75SE			500	200			△□	DC0129		15,30 kg	
Nozzle + ucbe DC75SE	DC0130 + DC0129								DC0179		31,60 kg

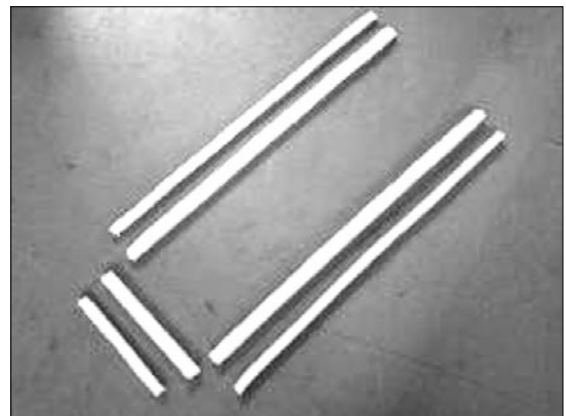
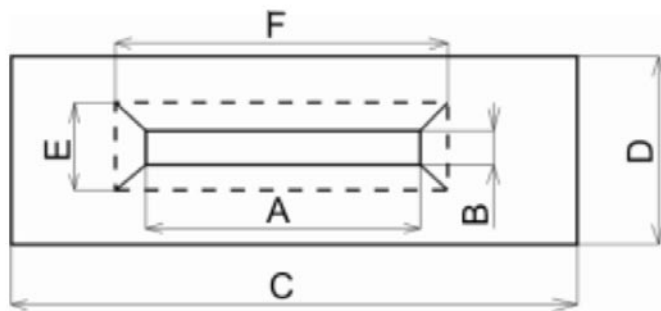

Sealing cords of insulation along nozzle (different types on boiler type) – supplied with nozzle (3 pcs)

**Table No. 14 - Side parts of the gasification chamber – for boilers GS**

Boiler type	Lenght	Amount of holes in the part	Amount of pieces	Code	Price	Weight
DC18GSE	392	3 + 2	2	DC0176		13,90 kg
DC20GS, DC22GSE, GS20	392	3	2	DC0161		13,50 kg
DC25GS, DC32GS, DC30GSE, GS25, GS32	292	3	4	DC0162		25,00 kg
DC25GSE - old version	392	4	2	DC0177		24,20 kg
DC25GSE - since 15.4.2012	292	2 + 2	4	DC0174		27,00 kg
DC40GS, DC40GSE, DC50GSE, GS40	292	4	4	DC0163		37,20 kg

### 3. Coal and wood gasification boilers



#### New grate

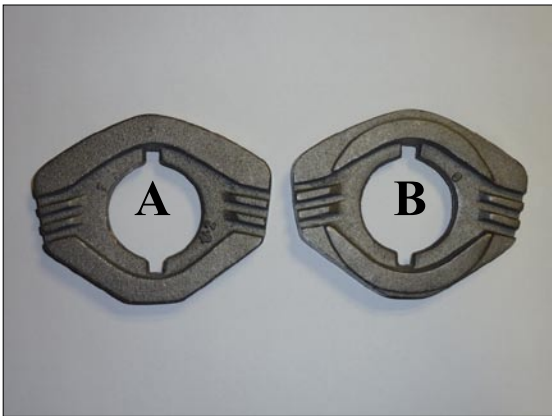

<b>Code: C0028</b> A) type - for all boilers ATMOS Combi – thick 24 mm – standard - except C40S, C50S - new version	<i>Price:</i> <i>Weight:</i> 1,54 kg
---	---

<b>Code: C0029</b> A) type - for all boilers ATMOS Combi – thin 20 mm – as an extra option - except C40S, C50S - new version	<i>Price:</i> <i>Weight:</i> 1,20 kg
--	---

<b>Code: C0027</b> B) type - first and last one, for all boilers ATMOS Combi - except C40S, C50S - new version	<i>Price:</i> <i>Weight:</i> 1,42 kg
--	---

#### New grate - with Cr

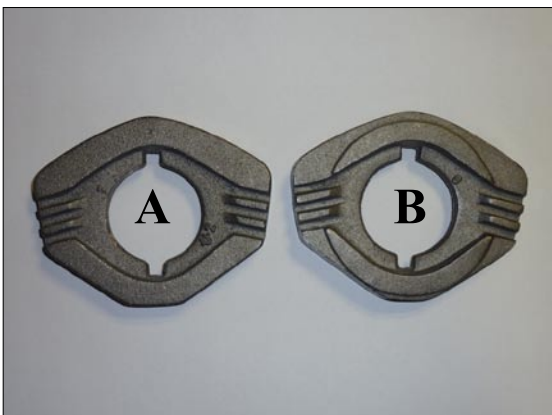

<b>Code: C0008</b> A) type - for all boilers AC25S, KC25S, AC35S, KC35S, AC45S, KC45S, C40S, C50S – thick 24 mm – with Cr	<i>Price:</i> <i>Weight:</i> 1,54 kg
---	---

<b>Code: C0009</b> A) type - for all boilers AC25S, KC25S, AC35S, KC35S, AC45S, KC45S, C40S, C50S – thin 20 mm – as an extra option – with Cr	<i>Price:</i> <i>Weight:</i> 1,20 kg
---	---

<b>Code: C0010</b> B) type - for all boilers AC25S, KC25S, AC35S, KC35S, AC45S, KC45S, C40S, C50S – preset grate– first and last one – with Cr	<i>Price:</i> <i>Weight:</i> 1,42 kg
--	---

#### Grate – standard (middle) – A), first – B) and last one – C) - old version

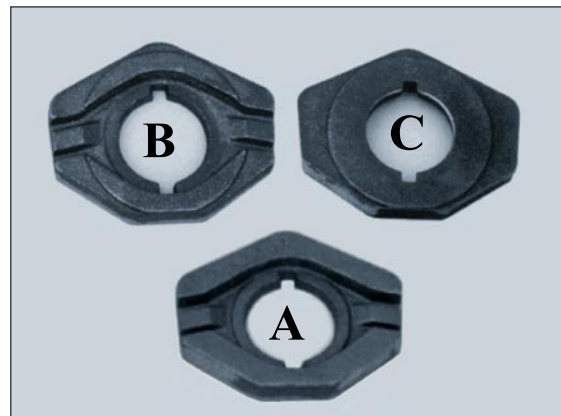

<b>Code: C0016</b> A) type - for all boilers ATMOS Combi – thick 24 mm – standard - except C40S, C50S - old version	<i>Price:</i> <i>Weight:</i> 1,54 kg
---	---

<b>Code: C0019</b> A) type - for all boilers ATMOS Combi – thin 20 mm – as an extra option - except C40S, C50S - old version	<i>Price:</i> <i>Weight:</i> 1,20 kg
--	---

<b>Code: C0017</b> B) type - first, for all boilers ATMOS Combi except C40S, C50S - old version	<i>Price:</i> <i>Weight:</i> 1,44 kg
---	---

<b>Code: C0018</b> C) type - last one, for all boilers ATMOS Combi - except C40S, C50S - old version	<i>Price:</i> <i>Weight:</i> 1,44 kg
--	---

#### Cast iron grate – DCxxR (S)



<b>Code: C0066</b> for boilers DC14R, DC24RS, DC30RS	<i>Price:</i> <i>Weight:</i> 1,54 kg
---	---



### Grate pipe



Table No. 15 on page 34

### Grate bar with handle



**Code: S0227** grate bar with handle

*Price:*

*Weight: 0,35 kg*

### Grate ceramic block



Table No. 16 on page 34

### Combustion chamber ceramic parts – DCxxR (S)

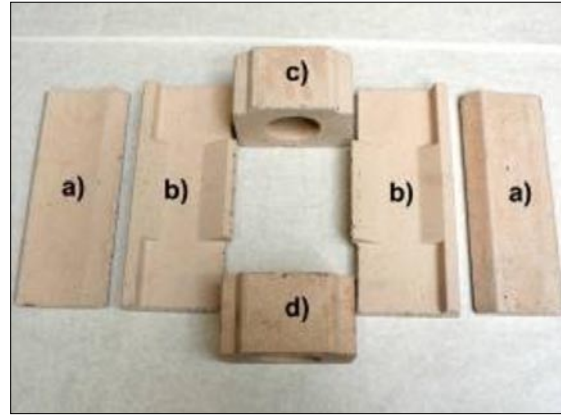

<b>Code: DC0019</b> c,d,) ceramic block for DC14R (front and rear side) – 1 piece	<i>Price:</i>
	<i>Weight: 5,86 kg</i>
<b>Code: DC0019</b> c) ceramic block for DC24RS. DC30RS (rear one) – 1 piece	<i>Price:</i>
	<i>Weight: 5,86 kg</i>
<b>Code: DC0020</b> d) ceramic block for DC24RS, DC30RS (front) –1 piece	<i>Price:</i>
	<i>Weight: 7,60 kg</i>
<b>Code: DC0156</b> b) ceramic block of the grate - left – 1pc	<i>Price:</i>
	<i>Weight: 5,80 kg</i>
<b>Code: DC0157</b> b) ceramic block of the grate - right – 1pc	<i>Price:</i>
	<i>Weight: 5,80 kg</i>
<b>Code: DC0155</b> b) ceramic block of the grate - (left+right) – 2pcs	<i>Price:</i>
	<i>Weight: 11,60 kg</i>
<b>Code: DC0145</b> a) insertion of the burning chamber – halfmoon – 2pcs	<i>Price:</i>
	<i>Weight: 6,64 kg</i>

### Rear face of the 4pcs spherical chamber – Combi



<b>Code: C0041</b> rear face of the 4pcs spherical chamber for boilers C20(S), C30(S), C40(S), DC15EP, DC18SP, DC25SP, DC32SP, AC35S, C50S, DC70GSX	<i>Price:</i>
	<i>Weight: 10,18 kg</i>
<b>Code: DC0168</b> rear face of the 4pcs spherical chamber for DC100 – with taller nose	<i>Price:</i>
	<i>Weight: 10,58 kg</i>

**A) Spherical ceramic chamber 4-pcs Combi L+R**



Table No. 17 on page 34

**Ceramic frame of the door**



**Code: DC0021** For all boilers type  
ATMOS Combi and ACxxS, KC25S

**Price:**  
**Weight:** 4,50 kg

**Table No. 14 - Grate pipe**

Boiler type	Amount of grates	Lenght	Code	Price	Weight
C18, C18S, AC25S, KC25S,	7	490	C0011		4,44 kg
C20, C20S, AC35S, KC35S	9	490	C0011		4,44 kg
C30, C30S, AC45S, KC45S	10	590	C0013		5,16 kg
C40, C40S	11	690	C0014		5,86 kg
C50S	11	650	C0015		5,50 kg
DC14R	4	490	C0067		4,58 kg
DC24RS, DC30RS	3	490	C0068		5,54 kg

**Table No. 15 - Grate ceramic block**

Boiler type	Grate ceramic block wide							
	In front side of the boiler				In rear side of the boiler			
	Lenght	Code	Price	Weight	Lenght	Code	Price	Weight
C18, C18S	108	C0021		5,56 kg	108	C0021		5,56 kg
C20, C20S, AC35S, KC35S	85	C0022		7,92 kg	85	C0022		7,92 kg
C30, C30S, AC45S, KC45S	120	C0023		11,32 kg	120	C0023		11,32 kg
C40, C40S, C50S	200	C0024		16,72 kg	120	C0023		11,32 kg
C80S	120	C0023		11,32 kg	120	C0023		11,32 kg
AC25S, KC25S	132	C0026		6,36 kg	132	C0026		6,36 kg

**Table No. 16 - Spherical ceramic chamber 4-pcs Combi Left+Right**

Boiler type	Lenght	Code CODE left side + right side + rear face	Price	Weight	Code only for left side + right side	Price	Weight
C18, C18S, AC25S, KC25S, DC14R, DC24RS, DC30RS	310 low profile	C0031		21,32 kg	C0036		14,76 kg
C20, C20S, DC15EP, DC18SP, AC35S	310	C0032		25,78 kg	C0037		16,46 kg
DC25SP, DC32SP	310 + 200	DC00171		25,78 kg	DC00172		20,56 kg
Prolonging of spherical ceramic chamber 200 mm for boiler DC25SP, DC32SP – separate (L + R side)					DC0169		4,60 kg
C30, C30S, AC45S	410	C0033		32,36 kg	C0038		23,66 kg
C40, C40S, C50S	510	C0034		37,76 kg	C0039		28,44 kg
C80S	510	C0034		37,76 kg	C0039		28,44 kg
DC100 - complete	510 + 180	C0035 - inc. prolonging		52,56 kg	C0040 - inc. prolonging		42,18 kg
Prolonging (180) Left and Right sides – for boilers DC100					C0051		13,78 kg

**Notice:** By boilers DC25SP and DC32SP the spherical ceramic chamber consists of standard spherical chamber C0032 + ceramic prolonging DC0169

## 4. Accessories



### Thermostat for putting on pipe



**Code: P0011** thermostat, for controlling pumps

*Price:*  
*Weight:* 0,16 kg

### Dual thermostat - IMIT



**Code: P0442** 542714 - thermostat T (0 - 90°C) / STB (90 - 110°C) IMIT in to the basin

*Price:*  
*Weight:* 0,30 kg

### Dual thermostat - stem - Honeywell

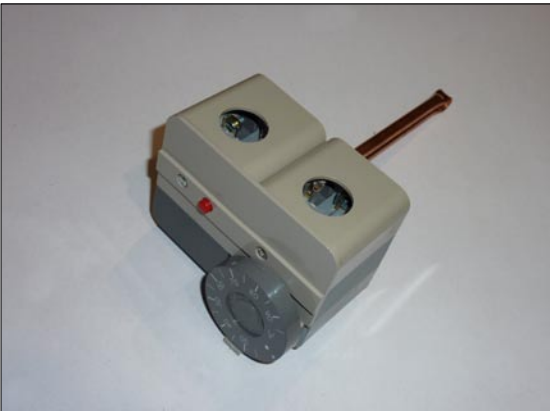

**Code: P0441** T/STB dual thermostat - stem - safety (40 - 110°C) + operation (30 - 90°C) - Honeywell

*Price:*  
*Weight:* 0,30 kg

### Dual thermostat - IMIT



**Code: P0443** 542708 - thermostat T (0 - 90°C) / STB (90 - 110°C) IMIT with 0,5m capillary

*Price:*  
*Weight:* 0,30 kg

### Thermometer



**Code: P0051** thermomet with connecting point

*Price:*  
*Weight:* 0,12 kg

### Thermometer for putting on pipe



**Code: P0340** thermometer for puttng on pipe D63 / 0 - 120°C

*Price:*  
*Weight:* 0,20 kg

### Manometer RA80-3/8" – 4 bar



**Code: S0084** Manometer for heating circuit - RA80-3/8" – 4 bar

*Price:*  
*Weight:* 0,12 kg

**Code: P0341** Manometer for heating circuit – D100 – 1/2" – 4 bar

*Price:*  
*Weight:* 0,24 kg

### Thermometer for buffer tank



**Code: P0076** thermometer for buffer tanks - lenght 150 mm

*Price:*  
*Weight:* 0,20 kg

### Waste gas thermometer



**Code: P0031** with basin – complete

*Price:*  
*Weight:* 0,30 kg

### Basins for buffer tanks



**Code: P0078** basin for one thermometer or one sensor - lenght 200 mm

*Price:*  
*Weight:* 0,08 kg

**Code: P0079** basin for three sensors – lenght 230 mm

*Price:*  
*Weight:* 0,07 kg

### Flue way with cleaning lid – thickness 5 mm



<b>Code: P0041</b> for all boilers with flue way socket diameter 152 mm (DC18S - DC50S (SE), DC18GSE - DC50GSE, DC22SX - DC40SX - délka 580 mm	<i>Price:</i>
	<i>Weight:</i> 12,22 kg

### Enamelled flue way



<b>Code: K0101</b> flue way - diameter 152 mm/1000 mm	<i>Price:</i>
	<i>Weight:</i> 5,02 kg
<b>Code: K0102</b> flue way - diameter 152 mm/500 mm	<i>Price:</i>
	<i>Weight:</i> 2,48 kg
<b>Code: K0103</b> flue way - diameter 152 mm/250 mm	<i>Price:</i>
	<i>Weight:</i> 1,26 kg
<b>Code: K0100</b> knee - diameter 152 mm/90°	<i>Price:</i>
	<i>Weight:</i> 1,66 kg
<b>Code: K0106</b> flue way - diameter 152 mm/1000 mm with cleaning hole	<i>Price:</i>
	<i>Weight:</i> 5,20 kg
<b>Code: K0107</b> flue way - diameter 152 mm/500 mm with cleaning hole	<i>Price:</i>
	<i>Weight:</i> 2,62 kg
<b>Code: K0108</b> flue way - diameter 152 mm/250 mm with cleaning hole	<i>Price:</i>
	<i>Weight:</i> 1,36 kg
<b>Code: K0104</b> knee - diameter 152 mm/45° with cleaning hole	<i>Price:</i>
	<i>Weight:</i> 1,84 kg
<b>Code: K0105</b> knee - diameter 152 mm/90° with cleaning hole	<i>Price:</i>
	<i>Weight:</i> 1,78 kg

### Flue way with cleaning lid



<b>Code: P0042</b> for all boilers with flue way socket diameter 200 mm (DC100)	<i>Price:</i>
	<i>Weight:</i> 7,60 kg
<b>Code: P0037</b> For all boilers with flue way socket diameter 180 mm (DC70S, DC75SE)	<i>Price:</i>
	<i>Weight:</i> 7,10 kg
For the straight connection for chimney (without knees)	

### Draght reducer for chimney



<b>Code: S0195</b> for reducing of drought in chimney, Ø 150 – 180 mm	<i>Price:</i>
	<i>Weight:</i> 0,90 kg

### Cleaning set – complete with brush



<b>Code: P0046</b> for ATMOS Combi and boilers with spherical combustion chamber (DCxxGS, DC15E, DC14R, DC24RS) - thin	<i>Price:</i>
	<i>Weight: 1,04 kg</i>
<b>Code: P0131</b> for ATMOS DCxxS (with ceramic roof) D15, D20 – wide type	<i>Price:</i>
	<i>Weight: 1,08 kg</i>
<b>Code: P0132</b> for ATMOS DC75SE	<i>Price:</i>
	<i>Weight: 1,36 kg</i>
<b>Code: P0054</b> for ATMOS DC100	<i>Price:</i>
	<i>Weight: 1,46 kg</i>
<b>Code: P0057</b> DC30RS, DCxxGSX	<i>Price:</i>
	<i>Weight: 1,80 kg</i>
<b>Code: P0070</b> D14P, D21P, D25P, P14, P21, P25, D31P, P31	<i>Price:</i>
	<i>Weight: 0,98 kg</i>

### Steel brushes



<b>Code: P0047</b> 35x70 mm - for all boilers: DC18S – DC75SE, C18S – C40S, DC22GSE – DC50GSE, AC25S, DC22SX-DC40SX	<i>Price:</i>
	<i>Weight: 0,10 kg</i>
<b>Code: P0048</b> Ø125 mm - for DC100, D15P, D20P, D30P, D45P, D30, DC30RS	<i>Price:</i>
	<i>Weight: 0,16 kg</i>
<b>Code: P0077</b> Ø96 mm – for D14P, D21P, D25P, P14, P21, P25, D31P, P31	<i>Price:</i>
	<i>Weight: 0,14 kg</i>
<b>Code: P0059</b> Ø65 mm – for DCxxGSE, C50S	<i>Price:</i>
	<i>Weight: 0,10 kg</i>

### Ash Pan



<b>Code: P0043</b> small – C18S, C20S, DC18S, DC20GS, DC18GSE, DC22GSE, DCxxRS, DC25GSE - old version	<i>Price:</i>
	<i>Weight: 1,60 kg</i>
<b>Code: P0044</b> big – C30S, C40S, DC25GS, DC32GS, DC40GS, DC30SE, DC100, DC30GSE, DC40GSE, DC50GSE, DC25GSE - since 15.4.2012	<i>Price:</i>
	<i>Weight: 2,18 kg</i>
<b>Code: P0052</b> big – DC15E	<i>Price:</i>
	<i>Weight: 2,30 kg</i>
<b>Code: P0060</b> big – boilers with ceramic roof part	<i>Price:</i>
	<i>Weight: 2,18 kg</i>

### Ash pan – for boiler - D

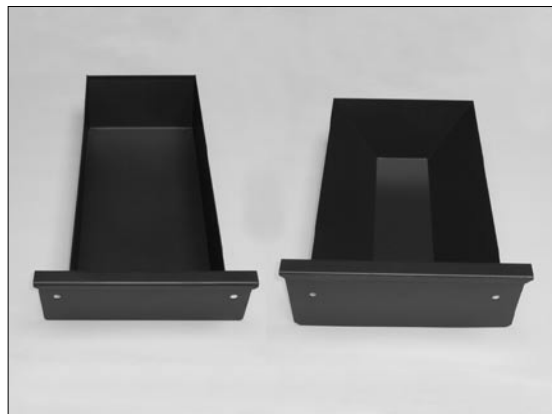

<b>Code: P0045</b> for boilers D15, D15P, D20P – old version small short	<i>Price:</i>
	<i>Weight: 2,20 kg</i>
<b>Code: S0492</b> for boilers D20 – old version small long	<i>Price:</i>
	<i>Weight: 2,56 kg</i>
<b>Code: P0065</b> for D15P, D20P, D15 - new big short (by types D15P, D20P from serial number 120000, by boilers D15 from 1.1. 2007)	<i>Price:</i>
	<i>Weight: 2,64 kg</i>
<b>Code: P0066</b> for boilers D20, D30, D30P, D1 – new big long (od 1.1 2007)	<i>Price:</i>
	<i>Weight: 2,92 kg</i>
<b>Code: P0068</b> for boiler D45P	<i>Price:</i>
	<i>Weight: 3,40 kg</i>
<b>Code: P0097</b> for boilers D14P, D21P, P14, P21	<i>Price:</i>
	<i>Weight: 3,32 kg</i>
<b>Code: P0080</b> for boilers D25P, P25, D31P, P31	<i>Price:</i>
	<i>Weight: 3,62 kg</i>

### Ashtray for cleaning tube plate of pellets boilers DxxP



**Code: S0548** serves for trouble less cleaning of pellets boilers D15P, D20P, D30P, D45P

<i>Price:</i>
<i>Weight:</i> 4,72 kg

### Cleaning fire hook - big

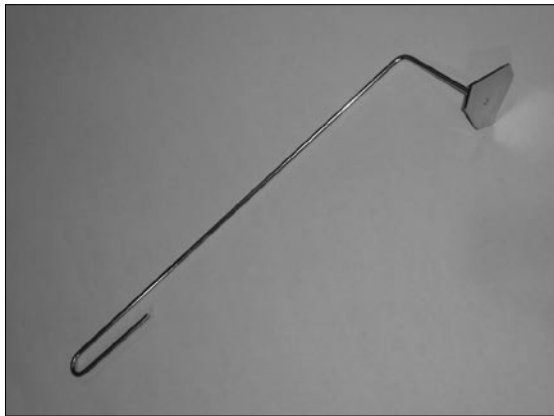

**Code: V0343** cleaning fire hook for cleaning burning chamber of the burner A25 or A45 - big

<i>Price:</i>
<i>Weight:</i> 0,26 kg

### Filling valve G1/2



**Code: P0211** fillinf valve for boilers

<i>Price:</i>
<i>Weight:</i> 0,12 kg

### Thermoregulating valve 60/61/65°C



Recommended sizing of valves

DC15E, C18S, DC22S, DC25S, DC25GS, C20S	- TV 25
DC32S, C30S, DC32GS, DC40GS, C40S	- TV 32
DC50S, DC80, DC70S	- TV 40

<b>Code: P0021</b> VTC511 25/60°C - DN25 - Kvs9 - ESBE – cast iron	<i>Price:</i>
	<i>Weight:</i> 0,86 kg
<b>Code: P0022</b> VTC511 32/60°C - DN32 - Kvs14 - ESBE - cast iron	<i>Price:</i>
	<i>Weight:</i> 1,06 kg
<b>Code: P0030</b> VTC512 40/60°C - DN40 - Kvs17 - ESBE - cast iron	<i>Price:</i>
	<i>Weight:</i> 1,38 kg
<b>Code: P0026</b> Spare thermostat cartridge into the do TV ventil ESBE	<i>Price:</i>
	<i>Weight:</i> 0,14 kg
<b>Code: P0027</b> TSV 2 DN50 – 61°C – Regulus – including screwing - brass	<i>Price:</i>
	<i>Weight:</i> 2,40 kg
<b>Code: P0029</b> TSV 3 DN32 – 65°C – Regulus – including screwing - brass	<i>Price:</i>
	<i>Weight:</i> 0,80 kg

### Three-way mixer



<b>Code: P0334</b> VDM3 DN25 – MUT – brass - screwing	<i>Price:</i>
	<i>Weight:</i> 1,04 kg
<b>Code: P0335</b> VDM3 DN32 – MUT – brass - screwing	<i>Price:</i>
	<i>Weight:</i> 1,05 kg
<b>Code: P0312</b> 3MG25 - ESBE – brass - screwing	<i>Price:</i>
	<i>Weight:</i> 0,70 kg
<b>Code: P0333</b> 3MG32 - ESBE – brass - screwing	<i>Price:</i>
	<i>Weight:</i> 1,03 kg
<b>Code: P0344</b> 3G32 – ESBE – cast iron - screwing	<i>Price:</i>
	<i>Weight:</i> 2,18 kg
<b>Code: P0343</b> 3G40 - ESBE – cast iron - screwing	<i>Price:</i>
	<i>Weight:</i> 1,70 kg

### Laddomat 21



<b>Code: P0101</b> using for up to 50kW	<i>Price:</i>
	<i>Weight:</i> 9,48 kg

#### Spare parts

<b>Code: P0103</b> spare cartridge 78°C	<i>Price:</i>
	<i>Weight:</i> 0,20 kg
<b>Code: P0104</b> spare cartridge 72°C	<i>Price:</i>
	<i>Weight:</i> 0,20 kg
<b>Code: P0105</b> pump WILO RS25/70r	<i>Price:</i>
	<i>Weight:</i> 1,64 kg
<b>Code: P0106</b> screwing of the closing valve (5/4")	<i>Price:</i>
	<i>Weight:</i> 0,40 kg
<b>Code: P0102</b> sealing under fitting	<i>Price:</i>
	<i>Weight:</i> 0,01 kg
<b>Code: P0107</b> thermometer	<i>Price:</i>
	<i>Weight:</i> 0,25 kg
<b>Code: P0109</b> O-ring for thermostat cartridge	<i>Price:</i>
	<i>Weight:</i> 0,02 kg
<b>Code: P0100</b> spare cartridge 63°C	<i>Price:</i>
	<i>Weight:</i> 0,20 kg
<b>Code: P0108</b> spare cartridge 83°C	<i>Price:</i>
	<i>Weight:</i> 0,20 kg
<b>Code: P0110</b> spare cartridge 87°C	<i>Price:</i>
	<i>Weight:</i> 0,20 kg
<b>Code: P0209</b> tube for locking the back flap	<i>Price:</i>
	<i>Weight:</i> 0,01 kg

### Stopvalve with a switch



<b>Code: P0384</b> Z-SF25-2M1-1" - closed without electric income	<i>Price:</i>
	<i>Weight:</i> 1,14 kg
<b>Code: P0385</b> O-SF25-2M1-1" - opened without electric income	<i>Price:</i>
	<i>Weight:</i> 1,16 kg

### Pump WILO RS25/4.3-180



<b>Code: P0061</b> pump	<i>Price:</i>
	<i>Weight:</i> 2,30 kg

### Thermostatic valve for cooling loop



<b>Code: P0073</b> Honeywell TS 131 - 3/4" ZA 110°C	<i>Price:</i>
	<i>Weight:</i> 0,93kg
<b>Code: P0081</b> Honeywell TS 131 - 3/4" ZA 95°C	<i>Price:</i>
	<i>Weight:</i> 0,76 kg
<b>Code: P0082</b> WATTS STS 20 - 3/4" 97°C	<i>Price:</i>
	<i>Weight:</i> 0,80 kg
<b>Code: P0089</b> Danfoss BVTS - 3/4"A 95°C	<i>Price:</i>
	<i>Weight:</i> 0,90 kg
<b>Code: P0090</b> Danfoss BVTS - 3/4"A 108°C	<i>Price:</i>
	<i>Weight:</i> 0,70 kg

### Electric heating spiral



<b>Code: P0125</b> TJ-M48x2 - 4,5 kW	<i>Price:</i>
	<i>Weight:</i> 2,10 kg
<b>Code: P0126</b> TJ-M48x2 - 6 kW	<i>Price:</i>
	<i>Weight:</i> 2,30 kg



### Eqvithermal controller ACD01

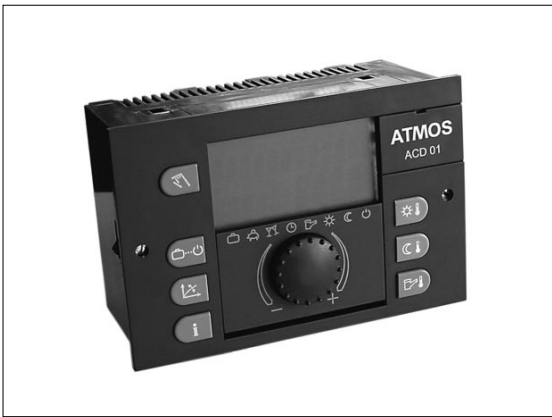

**Code: P0404** eqvithermal controller ACD01 *Price:*  
*Weight: 0,78 kg*

It is equithermal controll element for all boilers ATMOS burning solid fules, which is able to controll heating in two heating circuit, hot domestic water heating, solar heating by solar collectors, optima charging and discharging of accumulation tanks, authomatic switching between two boilers, (e.g. wood boiler and natural gas boiler) and commplet operation of the boiler, extraction ventilator when there is need in heating system.

### Connection terminal board SCS 12

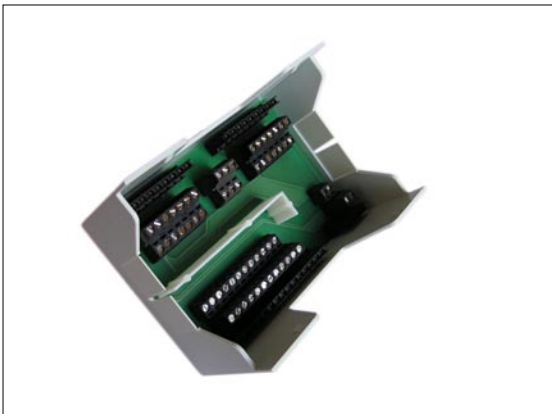

**Code: P0405** connection terminal board for eqvithermal controller ACD01 *Price:*  
*Weight: 0,36 kg*

### Backup without battery - 230V/12DC



**Code: P0212** UPS150/ext.-230V/12DC *Price:*  
*Weight: 5,52 kg*

equipment without a battery with the classical output of 230V, 230V output for the boiler or pump - ATMOS connector type and output of 12V (DC) for other applications (e.g security devices)

### GSM module-controller AB01 ATMOS



**Code: P0430** GSM module-controller AB01 ATMOS *Price:*  
*Weight: 1,60 kg*

It is a special multifunction unit, which is use for conntrolling and communication with different units in house or in weekend house over mobile phone(GSM). The main use is for remote controll of automatic heating systems with pellets, natural gas and oil boilers. It is special developed for controlling of four-status equithermal regulátor ATMOS ACD 01 or Honeywell type SMILE. It is also able to inform about outside temperature, interior temperature, heating system temperature and communication with other units and appliance. Modul is also equiped with program for optimal controll pellets boiler with acumulation tanks and with program for controll two or three boilers in cascade.

### Backup with battery - 230V/12DC



**Code: P0213** UPS100/3h-230V/12DC *Price:*  
*Weight: 19,42 kg*

**Code: P0214** UPS150/2h-230V/12DC *Price:*  
*Weight: 19,46 kg*

**Code: P0215** UPS250/8h-230V/12DC *Price:*  
*Weight: 35,72 kg*

**Code: P0216** UPS800/10h-230V/12DC *Price:*  
*Weight: 52,00 kg*

equipment with a battery with the classical output of 230V, 230V output for the boiler or pump - ATMOS connector type and output of 12V (DC) for other applications (e.g security devices)

## Pellet silo

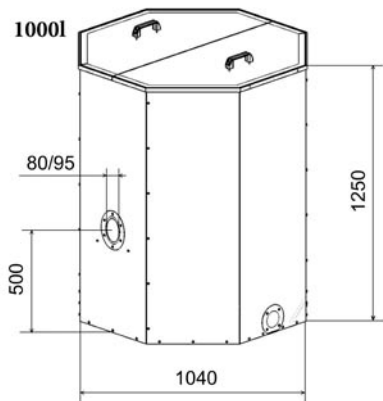
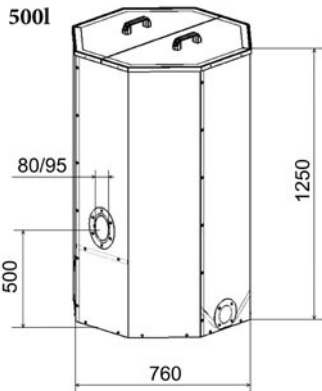
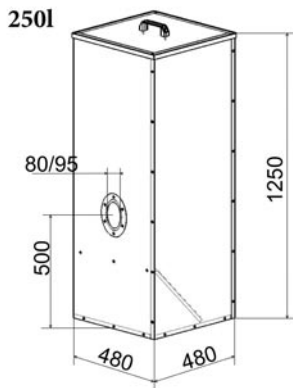

**Code: H0204** volume 250 l - red for conveyor ERATO, IWABO, DA1500/2000/2500, DA50, DRA50

*Price:*

*Weight:* 30,00 kg

**Code: H0201** volume 500 l - red for conveyor ERATO, IWABO, DA1500/2000/2500, DA50, DRA50

*Price:*

*Weight:* 48,00 kg

**Code: H0047** volume 1000 l - red for conveyor ERATO, IWABO, DA1500/2000/2500, DA50, DRA50

*Price:*

*Weight:* 68,00 kg

## Accumulation tanks

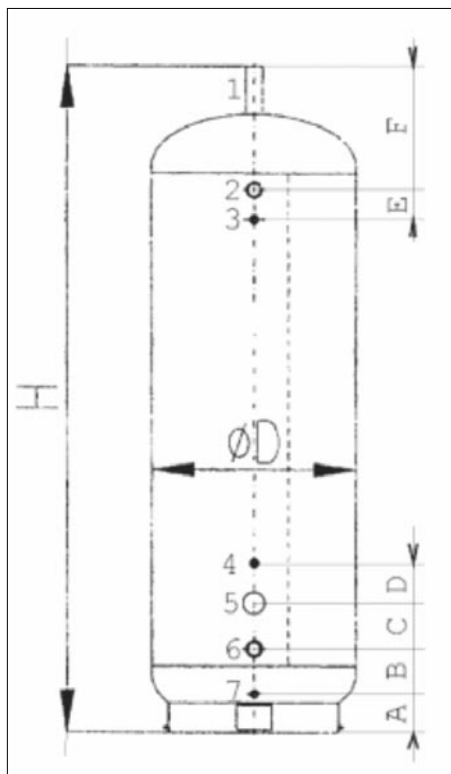

### Description:

Volume 500, 750, 800 a 1000 l

1. sleeve piece
2. upper outlet
3. sleeve for thermometer
4. sleeve for thermometer
5. sleeve for electric heating element
6. lower outlet
7. sleeve for bleeding valve

## New acumulation tanks type DH

### Dimensions of tanks type DH

Type	Dimension (mm)							Diameter (mm)							
	H	A	B	C	D	E	F	Ø D	1	2	3	4	5	6	7
AN 750	1752	140	95	110	130	90	366	790	5/4"	5/4"	1/2"	1/2"	M48x2	5/4"	1"
AN 800	1910	175	101	110	130	90	374	790	5/4"	5/4"	1/2"	1/2"	M48x2	5/4"	1"
AN 1000	2202	140	95	110	130	90	366	790	5/4"	5/4"	1/2"	1/2"	M48x2	5/4"	1"

### Uninsulated tanks type DH

Type	Code	Price	Weight
AN 750	P0170		120,00 kg
AN 800	P0199		116,00 kg
AN 1000	P0171		132,00 kg

### Insulated tanks type DH

Type	Code tank inc. insulation	Price	Weight	Code of sep. insulation	Price	Weight
AN 750	P0176		142,00 kg	P0173		22,00 kg
AN 800	P0201		138,00 kg	P0200		22,00 kg
AN 1000	P0177		161,00 kg	P0174		25,00 kg

**Uninsulated tanks with inner boiler for DHW 140 l – type DH**

Type	Code	Price	Weight
AN 500/2	P0178		
AN 750/2	P0179		
AN 800/2	P0202		160,00
AN 1000/2	P0180		

**Insulated tanks with inner boiler for DHW 140 l – type DH**

Type	Code tank inc. insulation	Price	Weight	Code of sep. insulation	Price	Weight
AN 500/2	P0184		kg	P0181		kg
AN 750/2	P0185		kg	P0182		kg
AN 800/2	P0204		185,00 kg	P0203		25,00 kg
AN 1000/2	P0186		kg	P0183		kg

**Uninsulated tanks with inner boiler for DHW 140 l and with coil for connecting solar – type DH**

Type	Code	Price	Weight
AN 500/3	P0187		
AN 750/3	P0188		
AN 800/3 - 2,3m <sup>2</sup>	P0205		170,00 kg
AN 1000/3	P0189		

**Insulated tanks with inner boiler for DHW 140 l and with coil for connecting solar – type DH**

Type	Code tank inc. insulation	Price	Weight	Code of sep. insulation	Price	Weight
AN 500/3	P0193		kg	P0190		kg
AN 750/3	P0194		kg	P0191		kg
AN 800/3 - 2,3m <sup>2</sup>	P0207		196,00 kg	P0206		25,00 kg
AN 1000/3	P0195		kg	P0192		kg

**Acumulation tanks type DZ**
**Dimensions of tanks type DZ**

Type	Dimension (mm)							Diameter (mm)							
	H	A	B	C	D	E	F	Ø D	1	2	3	4	5	6	7
AN 500	1944	127	131	110	130	90	326	600	5/4"	5/4"	1/2"	1/2"	M48x2	5/4"	1/2"
AN 750	1974	154	131	110	130	90	329	750	5/4"	5/4"	1/2"	1/2"	M48x2	5/4"	1/2"
AN 800	1910	175	101	110	130	90	374	790	5/4"	5/4"	1/2"	1/2"	M48x2	5/4"	1"
AN 1000	2025	175	108	110	130	90	342	850	5/4"	5/4"	1/2"	1/2"	M48x2	5/4"	1/2"

**Uninsulated tanks type DZ**

Type	Code	Price	Weight
AN 500	P0139		91,00 kg
AN 750	P0140		120,00 kg
AN 800	P0199		116,00 kg
AN 1000	P0141		136,00 kg

**Insulated tanks type DZ**

Type	Code	Price	Weight
AN 500/3	P0142		114,00 kg
AN 750/3	P0143		144,00 kg
AN 800/3 - 2,3m <sup>2</sup>	P0201		138,00 kg
AN 1000/3	P0144		161,00 kg

**Uninsulated tanks with inner boiler for DHW 200 l (expect AN 800/2 – 140 l) – type DZ**

Type	Code	Price	Weight
AN 500/2	P0145		133,00 kg
AN 750/2	P0146		168,00 kg
AN 800/2	P0202		160,00 kg
AN 1000/2	P0147		181,00 kg

**Insulated tanks with inner boiler for DHW 200 l (expect AN 800/2 – 140 l) – type DZ**

Type	Code	Price	Weight
AN 500/2	P0148		156,00 kg
AN 750/2	P0149		198,00 kg
AN 800/2	P0204		185,00 kg
AN 1000/2	P0150		206,00 kg

**Uninsulated tanks with inner boiler for DHW 140 l and with coil for connecting solar – type DZ**

Type	Code	Price	Weight
AN 500/3 - 1,7 m <sup>2</sup>	P0160		151,00 kg
AN 750/3 - 2,3 m <sup>2</sup>	P0161		185,00 kg
AN 800/3 - 2,3 m <sup>2</sup>	P0205		170,00 kg
AN 1000/3 - 3,3 m <sup>2</sup>	P0162		217,00 kg

**Insulated tanks with inner boiler for DHW 140 l and with coil for connecting solar – type DZ**

Type	Code	Price	Weight
AN 500/3 - 1,7 m <sup>2</sup>	P0163		174,00 kg
AN 750/3 - 2,3 m <sup>2</sup>	P0164		215,00 kg
AN 800/3 - 2,3 m <sup>2</sup>	P0207		196,00 kg
AN 1000/3 - 3,3 m <sup>2</sup>	P0165		242,00 kg

**Tank type DZ** – product of company DZ Dražice - CZ

**Tank type DH** – product of company HUCH or Dražice – DE/CZ

## 5. Pellet burner ATMOS A25



### Pellet burner ATMOS A25



<b>Code: H0014</b> burner – red - (4 - 24 kW)	<i>Price:</i>
	<i>Weight:</i> 17,66 kg
<b>Code: H0238</b> fuse for ignitaton spiral – type F3.15A/1500A/5x20 mm – into the burner	<i>Price:</i>
	<i>Weight:</i> 0,01 kg
<b>Code: H0239</b> fuse for ventilator or conveyor spiral – type F0.8A/1500A/5x20 mm	<i>Price:</i>
	<i>Weight:</i> 0,01 kg
<b>Code: H0251</b> fuse for conveyor – type F1.0A/1500A/5x20 mm	<i>Price:</i>
	<i>Weight:</i> 0,01 kg

### Conveyors for burner ATMOS A25



<b>Code: H0151</b> pellet conveyor DA1500 - 1,5 m	<i>Price:</i>
	<i>Weight:</i> 11,50 kg
<b>Code: H0207</b> pellet conveyor DA2000 - 2 m	<i>Price:</i>
	<i>Weight:</i> 13,00 kg
<b>Code: H0208</b> pellet conveyor DA2500 - 2,5 m	<i>Price:</i>
	<i>Weight:</i> 14,00 kg

### Electronic unit of the burner

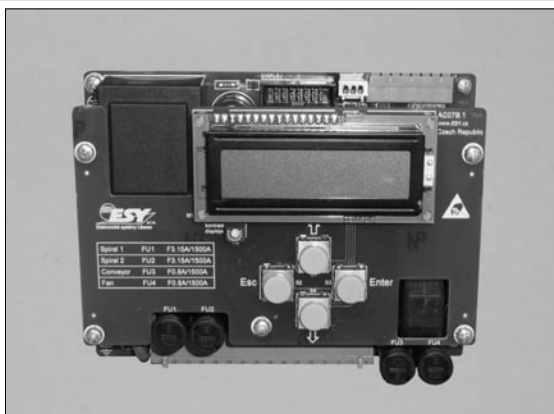

<b>Code: H0222</b> spare electronic unit of the burner - AC07 (ACO7X - since 2012) with a fixation plate	<i>Price:</i>
	<i>Weight:</i> 0,09 kg

### Gear box of the conveyor DAxxxx



<b>Code: H0107</b> gear box of the conveyor 25W for conveyors DA1500, DA2000, DA2500 diameter of the shaft - 10 mm	<i>Price:</i>
	<i>Weight:</i> 2,72 kg

### Incoming feeding pipe

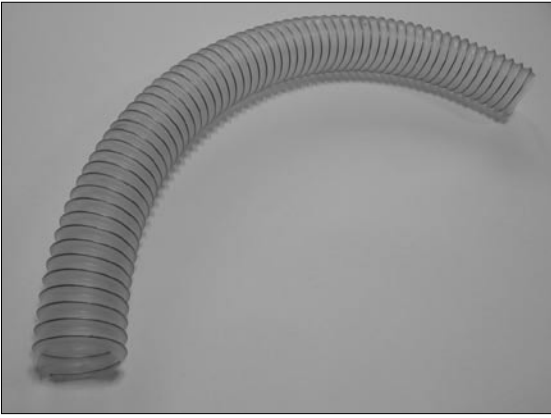

**Code: H0066** spare pipe between burner and pellet conveyor - lenght 1 m and Ø 65 mm - transparent

<i>Price:</i>
<i>Weight:</i> 0,68 kg

### Leg and flange for conveyors - type DA



<b>Code: S0992</b> flange – separate for conveyors DAxxxx	<i>Price:</i>
	<i>Weight:</i> 1,60 kg
<b>Code: H0414</b> leg for conveyor DA - DA2000 and DA2500	<i>Price:</i>
	<i>Weight:</i> 2,30 kg

### Spare spiral for conveyor DAxxxx

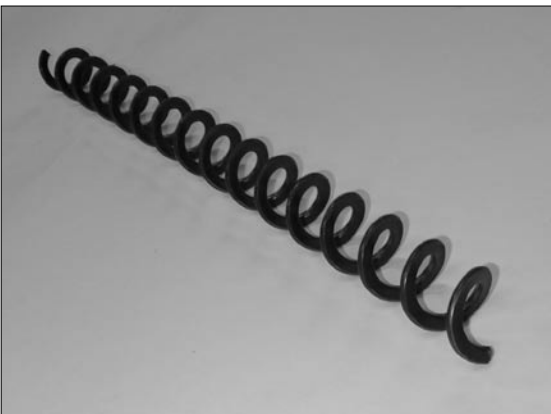

<b>Code: H0254</b> spiral for conveyor DA1500	<i>Price:</i>
	<i>Weight:</i> 1,08 kg
<b>Code: H0255</b> spiral for conveyor DA2000	<i>Price:</i>
	<i>Weight:</i> 1,42 kg
<b>Code: H0256</b> spiral for conveyor DA2500	<i>Price:</i>
	<i>Weight:</i> 1,76 kg

### Elements for conection spiral of the conveyor type DAxxxx - diameter of the shaft - 10 mm



<b>Code: H0257</b> complete set – element for cennection spiral to the gear box of engine 25 W + spare special screw (hook), nut and washer + grub screw (2pcs)	<i>Price:</i>
	<i>Weight:</i> 0,25 kg
<b>Code: V0892</b> separate spare element - 1 pc	<i>Price:</i>
	<i>Weight:</i> 0,22 kg
<b>Code: H0259</b> special screw (hook),nut and washer – 1pc	<i>Price:</i>
	<i>Weight:</i> 0,02 kg
<b>Code: S1001</b> grub screw M5 – 1pc	<i>Price:</i>
	<i>Weight:</i> 0,01 kg

### Transparent tube for conveyor DAxxxx

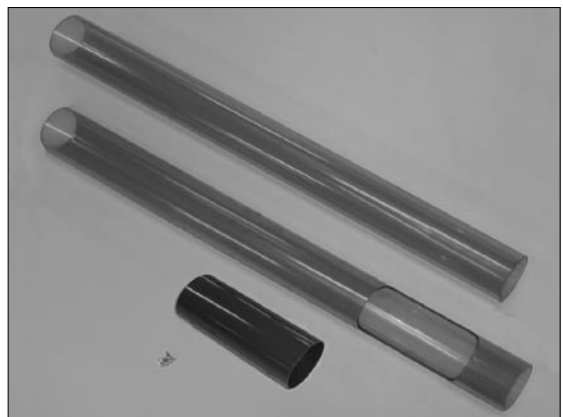

<b>Code: H0261</b> transparent tube 1 m – without recess	<i>Price:</i>
	<i>Weight:</i> 1,14 kg
<b>Code: H0253</b> transparent tube 1 m – with recess	<i>Price:</i>
	<i>Weight:</i> 1,20 kg
<b>Code: H0252</b> transparent tube 1,5 m – with recess	<i>Price:</i>
	<i>Weight:</i> 1,68 kg
<b>Code: H0240</b> transparent tube 2 m – with recess	<i>Price:</i>
	<i>Weight:</i> 2,26 kg
<b>Code: H0241</b> transparent tube 2,5 m – with recess	<i>Price:</i>
	<i>Weight:</i> 2,84 kg
<b>Code: V0120</b> conection for tubes - H0261 and H253 with 6 screws	<i>Price:</i>
	<i>Weight:</i> 0,80 kg

### Fan with a speed sensor and with air flap

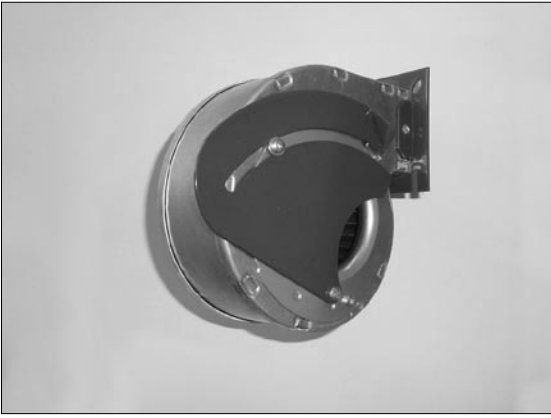

**Code: H0058** fan with a speed sensor and with air flap

*Price:*

*Weight:* 1,12 kg

### Combustion chamber (pot) of the burner

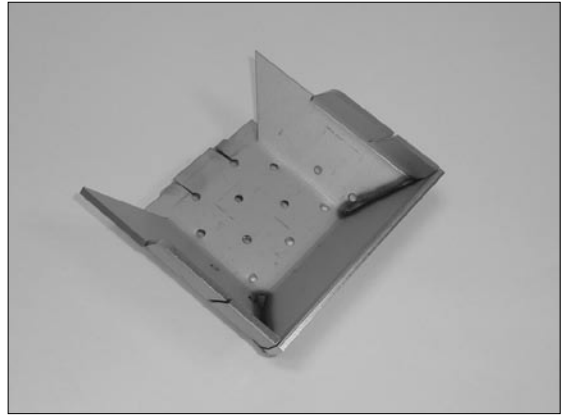

**Code: H0228** combustion chamber (pot) of the burner from serial number 160

*Price:*

*Weight:* 0,84 kg

**Code: H0053** combustion chamber (pot) of the burner to serial number 160

*Price:*

*Weight:* 0,80 kg

### Air flap of the fan

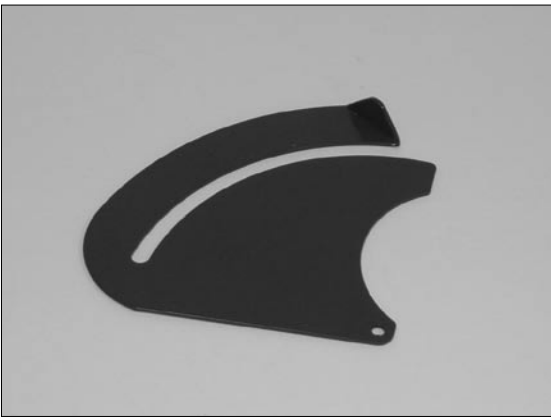

**Code: H0230** air flap of the fan

*Price:*

*Weight:* 0,10 kg

### Holder - plate with openings for the ignition spirals



**Code: H0225** holder - plate with openings for the ignition spirals

*Price:*

*Weight:* 0,85 kg

### Top cover of the burner mouth

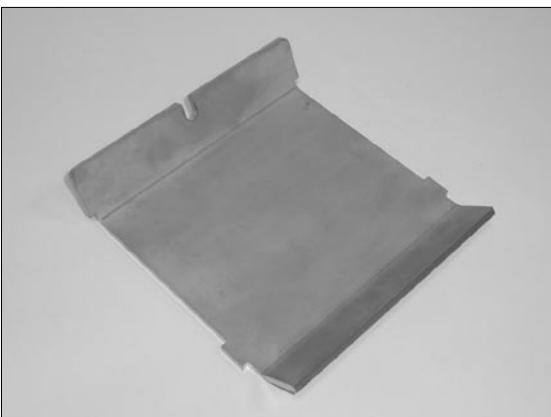

**Code: H0220** top cover of the burner mouth

*Price:*

*Weight:* 0,87 kg

### Inner holder of the ignition spiral

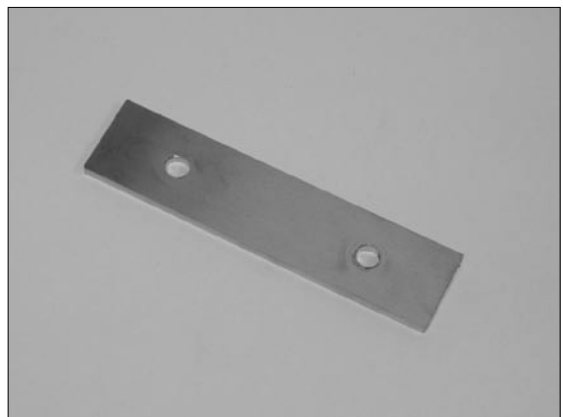

**Code: H0227** inner holder of the ignition spiral

*Price:*

*Weight:* 0,11 kg



### Ignition spiral cover

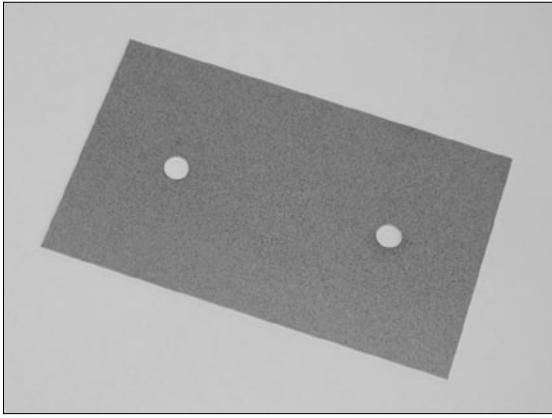

**Code: H0226** ignition spiral cover

*Price:*

*Weight: 0,08 kg*

### End switch stop



**Code: H0237** end switch stop

*Price:*

*Weight: 0,06 kg*

### Ignition spiral



**Code: H0229** spare ignition spiral 500W

*Price:*

*Weight: 0,18 kg*

### Pellet supply pipe



**Code: H0223** pellet supply pipe

*Price:*

*Weight: 0,60 kg*

### End switch of the burner



**Code: H0210** end switch of the burner  
- FR501

*Price:*

*Weight: 0,08 kg*

### Gasket under the flange of the pellet supply pipe



**Code: S0170** gasket under the flange of the  
pellet supply pipe - sibral paper

*Price:*

*Weight: 0,01 kg*

### Safety thermostat cover

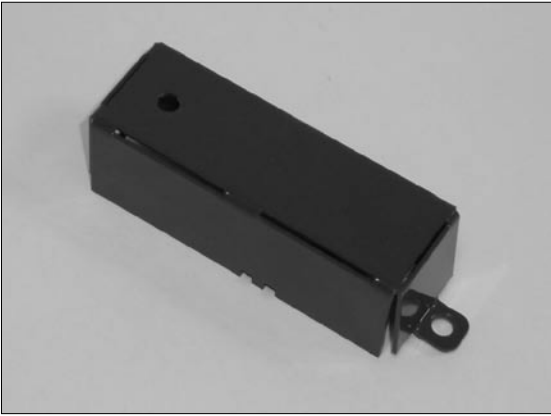

**Code: H0224** safety thermostat cover

*Price:*

*Weight: 0,05 kg*

### Holder of the electronic unit

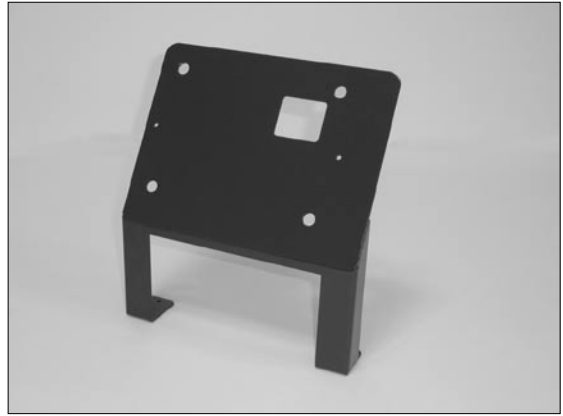

**Code: H0221** holder of the electronic unit

*Price:*

*Weight: 0,70 kg*

### Safety thermostat 95°C



**Code: H0059** safety thermostat to burner supply pipe (two possible types) - can be changed

*Price:*

*Weight: 0,02 kg*

### Burner cover - hood with a window for the display

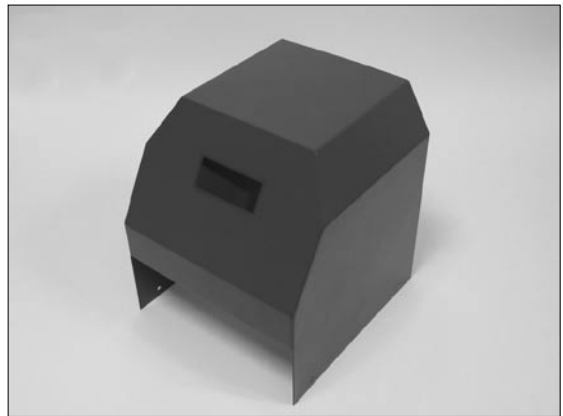

**Code: H0219** burner cover - hood with a window for the display

*Price:*

*Weight: 1,50 kg*

**Code: H0274** burner cover - hood with a window for the display - model 2012 (AC07X)

*Price:*

*Weight: 1,50 kg*

### Socket for the external conveyor



**Code: H0211** socket for the external conveyor

*Price:*

*Weight: 0,05 kg*

### Display self-sticking label



**Code: H0236** display self-sticking label

*Price:*

*Weight: 0,01 kg*

### Electric wiring of the burner

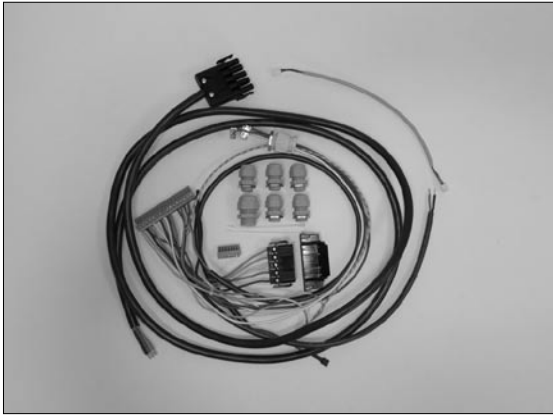

<b>Code: H0216</b> electric wiring of the burner, incl. bushings and connectors	<i>Price:</i>
	<i>Weight:</i> 1,00 kg

### Photocell



<b>Code: H0231</b> spare photocell	<i>Price:</i>
	<i>Weight:</i> 0,05 kg
<b>Code: H0232</b> photocell holder	<i>Price:</i>
	<i>Weight:</i> 0,02 kg
<b>Code: H0055</b> photocell with holdre - complete	<i>Price:</i>
	<i>Weight:</i> 0,07 kg

### AC07 electronic unit connector (1 - 16) PIN – bottom



<b>Code: H0234</b> electronic unit connector (1 - 16) - bottom	<i>Price:</i>
	<i>Weight:</i> 0,03 kg

### Suply burner connector with lid

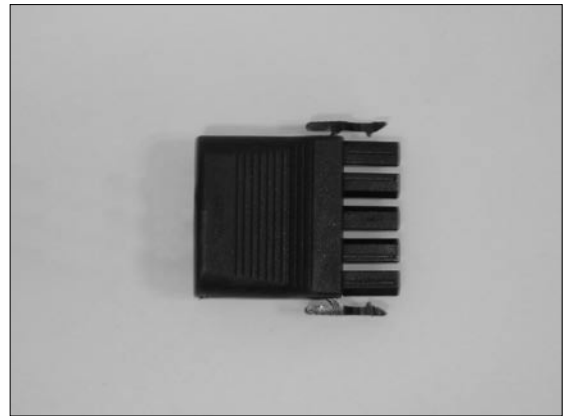

<b>Code: S0902</b> connector (NAC 52S.B) female with cabel – 5-pin	<i>Price:</i>
	<i>Weight:</i> 0,44 kg

### AC07 and AC07X electronic unit connector

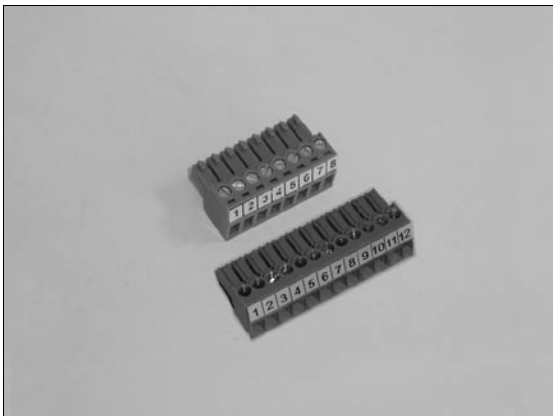

<b>Code: H0235</b> electronic unit connector (1 - 8) - top for unit AC07	<i>Price:</i>
	<i>Weight:</i> 0,01 kg
<b>Code: H0260</b> electronic unit connector (1 - 12) - top for unit AC07X	<i>Price:</i>
	<i>Weight:</i> 0,01 kg

### Burner connector with bushing

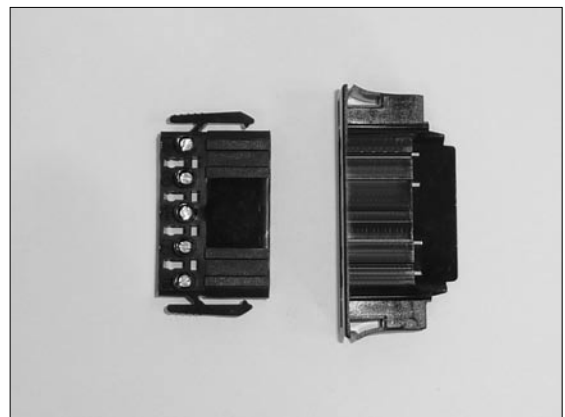

<b>Code: S0914</b> connector (NAC 51.B) – male with bushing – 5-pin	<i>Price:</i>
	<i>Weight:</i> 0,02 kg

### Suply burner connector with lid



**Code: S0991** connector - female for cabel  
- 6-pin - model 2012 (AC07X)

**Price:**  
**Weight:** 0,02 kg

### Konektor hořáku pro čidla s průchodkou

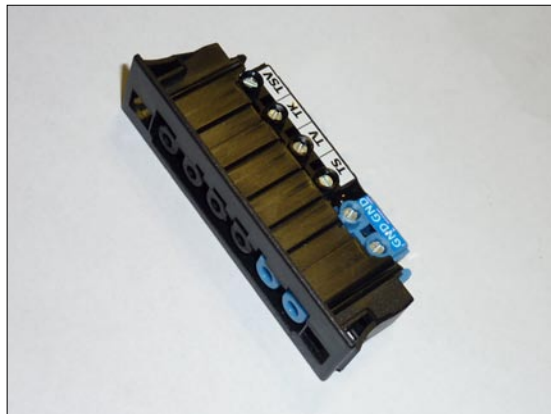

**Code: S0987** 6-pin connector with  
bushing - female - for sensors TSV,  
TK, TV and TS - for model 2012 with control unit AC07X

**Price:**  
**Weight:** 0,02 kg

### Burner connector with bushing



**Code: S0989** connector - male - 6-pin  
- model 2012 (AC07X)

**Price:**  
**Weight:** 0,02 kg

### Cleaning fire hook - small



**Code: V0346** fire hook for cleaning burning  
chamber of the burner A25 or A45 - small

**Price:**  
**Weight:** 0,12 kg

### Entrance connector for sensors with lid



**Code: S0988** 6-pin connector - male  
- for sensors TSV, TK, TV and TS  
- for model 2012 with control unit AC07X

**Price:**  
**Weight:** 0,02 kg

### Closing lid



**Code: S0509** intended for closing the air  
entrance when burning wood in boiler  
types DC15EP, DC18SP, DC25SP, DC32SP - for burners  
ATMOS A25 and IWABO VILLA S1

**Price:**  
**Weight:** 0,20 kg

## 6. Pellet burner ATMOS A45



### Pellet burner ATMOS A45



<b>Code: H0015</b> burner - red - (8,5 - 49 kW)	<i>Price:</i>
	<i>Weight: 23,00 kg</i>
<b>Code: H0238</b> fuse for ignitaton spiral – type F3.15A/1500A/5x20 mm – into the burner	<i>Price:</i>
	<i>Weight: 0,01 kg</i>
<b>Code: H0239</b> fuse for ventilator or conveyor spiral – type F0.8A/1500A/5x20 mm	<i>Price:</i>
	<i>Weight: 0,01 kg</i>
<b>Code: H0251</b> fuse for conveyor – type F1.0A/1500A/5x20 mm	<i>Price:</i>
	<i>Weight: 0,01 kg</i>

### Conveyors for burner ATMOS A25



<b>Code: H0039</b> conveyor for burner with shaft DRA50 - 1,7 m	<i>Price:</i>
	<i>Weight: 17,00 kg</i>
<b>Code: H0037</b> conveyor for burner with shaft DRA50 - 2,5 m	<i>Price:</i>
	<i>Weight: 23,00 kg</i>
<b>Code: H0004</b> conveyor for burner with shaft DRA50 - 4 m	<i>Price:</i>
	<i>Weight: 36,80 kg</i>
<b>Code: H0005</b> conveyor for burner with shaft DRA50 - 5 m	<i>Price:</i>
	<i>Weight: 40,00 kg</i>

### Electronic unit of the burner

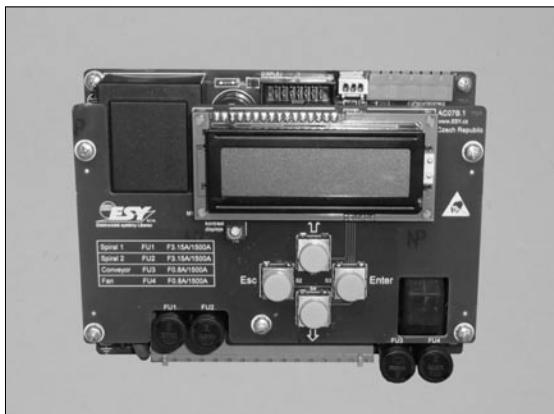

<b>Code: H0222</b> spare electronic unit of the burner - AC07 (ACO7X - since 2012) with a fixation plate	<i>Price:</i>
	<i>Weight: 0,09 kg</i>

### Gear box of the conveyor DRxxxx



<b>Code: H0107</b> gear box of the conveyor 25W - DRA50 - 1,7 a 2,5 m	<i>Price:</i>
	<i>Weight: 2,72 kg</i>
<b>Code: H0159</b> gear box of the conveyor 40W - DRA50 - 4 a 5 m	<i>Price:</i>
	<i>Weight: 4,50 kg</i>

### Incoming feeding pipe

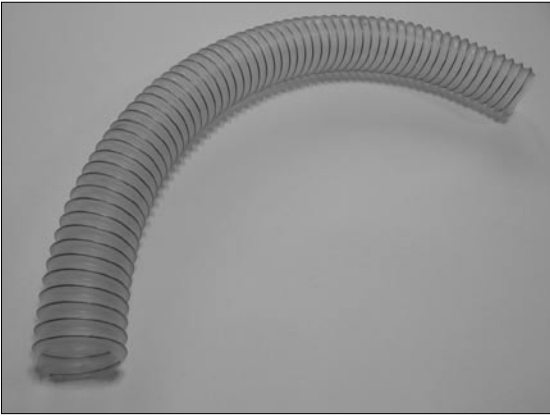

<b>Code: H0175</b> spare pipe between burner and pellet conveyor - lenght 1 m and Ø 75 mm - transparent	<i>Price:</i>
	<i>Weight: 0,78 kg</i>

### Leg and collar for conveyors - type DRA



<b>Code: H0416</b> collar – separate for conveyors DRA	<i>Price:</i>
	<i>Weight: 0,20 kg</i>
<b>Code: H0415</b> leg for conveyor type DRA - for conveyors DRA1,7 m, DRA2,5 m, DRA 4 m, DRA 5 m and DA1500	<i>Price:</i>
	<i>Weight: 2,10 kg</i>

### Spare auger with shaft for conveyor DRA50



<b>Code: H0007</b> spare auger for conveyor 1,7 m	<i>Price:</i>
	<i>Weight: 4,41 kg</i>
<b>Code: H0008</b> spare auger for conveyor 2,5 m	<i>Price:</i>
	<i>Weight: 6,26 kg</i>
<b>Code: H0009</b> spare auger for conveyor 4 m	<i>Price:</i>
	<i>Weight: 8,45 kg</i>
<b>Code: H0010</b> spare auger for conveyor 5 m	<i>Price:</i>
	<i>Weight: 10,28 kg</i>

### Spare bearing for conveyor



<b>Code: V0104</b> bearing	<i>Price:</i>
	<i>Weight: 0,12 kg</i>
<b>Code: V0105</b> pocket - 2 pcs	<i>Price:</i>
	<i>Weight: 0,10 kg</i>
<b>Code: H0198</b> complete set - bearing + pocket - 2 pcs	<i>Price:</i>
	<i>Weight: 0,22 kg</i>

### Spare tube of conveyor DRA50

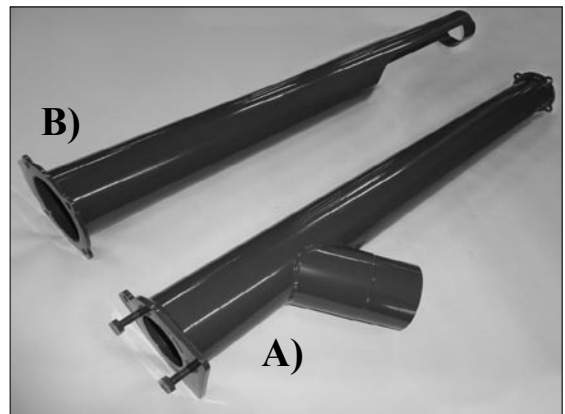

<b>Code: H0267</b> spare tube of conveyor DRA50 - 1,7 m	<i>Price:</i>
	<i>Weight: 5,87 kg</i>
<b>Code: H0268</b> spare tube of conveyor DRA50 - 2,5 m	<i>Price:</i>
	<i>Weight: 8,19 kg</i>
<b>Code: H0269</b> spare tube of conveyor DRA50 - 4 m - part A)	<i>Price:</i>
	<i>Weight: 6,65 kg</i>
<b>Code: H0270</b> spare tube of conveyor DRA50 - 4 m - part B)	<i>Price:</i>
	<i>Weight: 6,22 kg</i>
<b>Code: H0271</b> spare tube of conveyor DRA50 - 5 m - part A)	<i>Price:</i>
	<i>Weight: 8,09 kg</i>
<b>Code: H0272</b> spare tube of conveyor DRA50 - 5 m - part B)	<i>Price:</i>
	<i>Weight: 7,66 kg</i>

### Fan with a speed sensor and with air flap

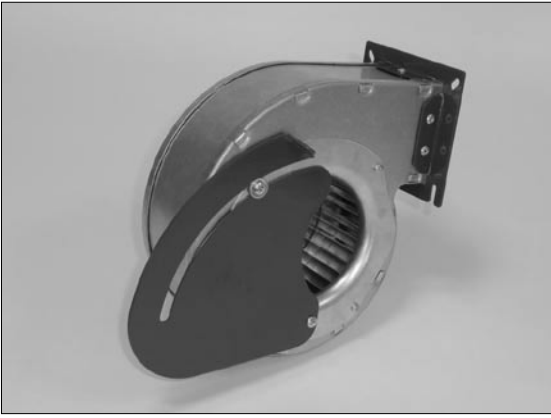

**Code: H0041** spare fan with a speed sensor and with air flap

<i>Price:</i>
<i>Weight: 2,04 kg</i>

### Combustion chamber (pot) of the burner

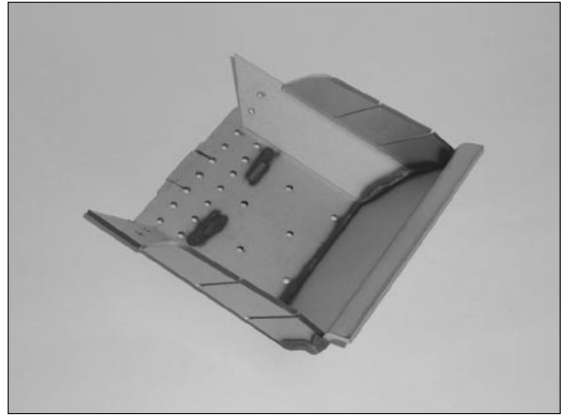

**Code: H0410** spare combustion chamber (pot) of the burner

<i>Price:</i>
<i>Weight: 2,00 kg</i>

### Air flap of the fan



**Code: H0441** air flap of the fan

<i>Price:</i>
<i>Weight: 0,16 kg</i>

### Holder - plate with openings for the ignition spirals

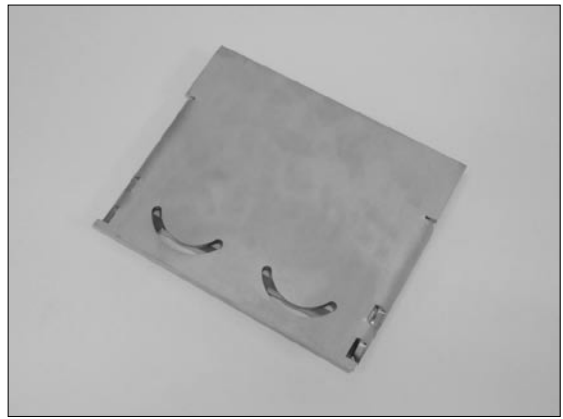

**Code: H0407** holder - plate with openings for the ignition spirals

<i>Price:</i>
<i>Weight: 1,26 kg</i>

### Top cover of the burner mouth

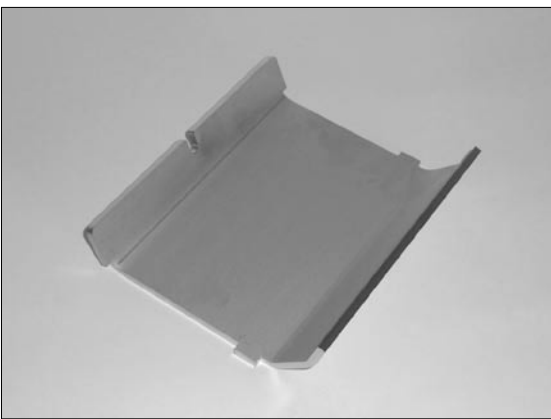

**Code: H0404** top cover of the burner mouth

<i>Price:</i>
<i>Weight: 1,48 kg</i>

### Inner holder of the ignition spiral

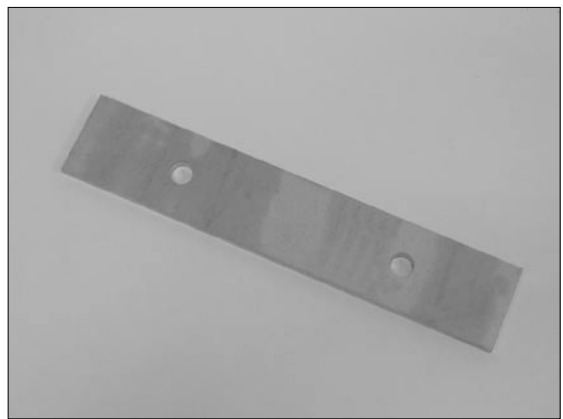

**Code: H0409** inner holder of the ignition spiral

<i>Price:</i>
<i>Weight: 0,14 kg</i>

### Ignition spiral cover

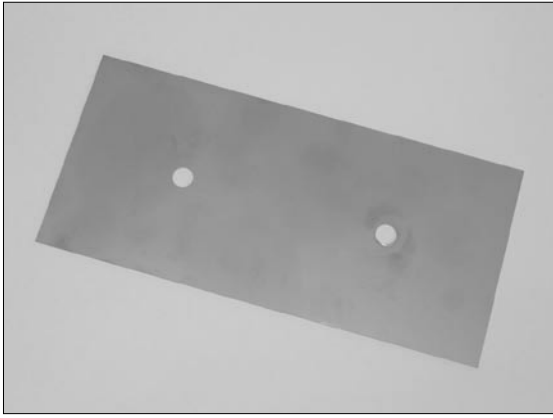

**Code: H0408** ignition spiral cover

*Price:*

*Weight: 0,10 kg*

### End switch stop



**Code: H0412** end switch stop

*Price:*

*Weight: 0,07 kg*

### Ignition spiral



**Code: H0229** spare ignition spiral 500W

*Price:*

*Weight: 0,18 kg*

### Pellet supply pipe



**Code: H0406** pellet supply pipe

*Price:*

*Weight: 0,72 kg*

### End switch of the burner



**Code: H0210** end switch of the burner  
- FR501

*Price:*

*Weight: 0,08 kg*

### Gasket under the flange of the pellet supply pipe



**Code: S0181** gasket under the flange of the  
pellet supply pipe - sibral paper

*Price:*

*Weight: 0,01 kg*



### Safety thermostat cover



**Code: H0224** safety thermostat cover

*Price:*

*Weight: 0,05 kg*

### Holder of the electronic unit

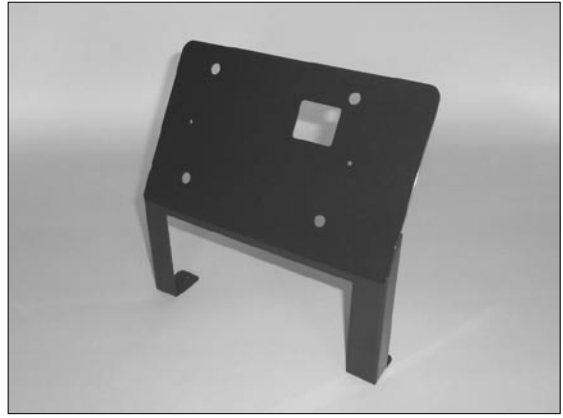

**Code: H0405** holder of the electronic unit

*Price:*

*Weight: 0,54 kg*

### Safety thermostat 95°C



**Code: H0059** safety thermostat to burner supply pipe (two possible types) - can be changed

*Price:*

*Weight: 0,02 kg*

### Burner cover - hood with a window for the display

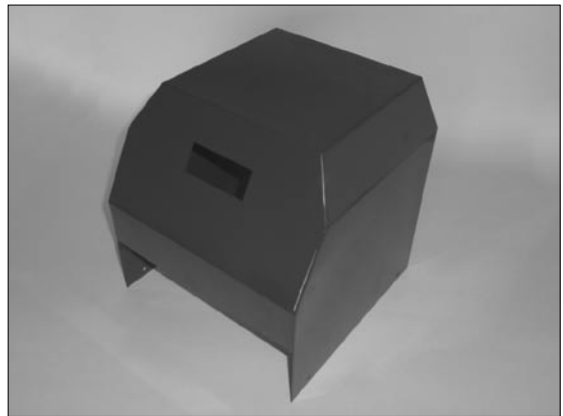

**Code: H0403** burner cover - hood with a window for the display

*Price:*

*Weight: 1,76 kg*

**Code: H0413** burner cover - hood with a window for the display - model 2012 (AC07X)

*Price:*

*Weight: 1,76 kg*

### Socket for the external conveyor



**Code: H0211** socket for the external conveyor

*Price:*

*Weight: 0,05 kg*

### Display self-sticking label



**Code: H0236** display self-sticking label

*Price:*

*Weight: 0,01 kg*

### Electric wiring of the burner



<b>Code: H0216</b> electric wiring of the burner, incl. bushings and connectors	<i>Price:</i>
	<i>Weight:</i> 1,00 kg

### Photocell



<b>Code: H0231</b> spare photocell	<i>Price:</i>
	<i>Weight:</i> 0,05 kg
<b>Code: H0232</b> photocell holder	<i>Price:</i>
	<i>Weight:</i> 0,02 kg
<b>Code: H0055</b> photocell with holdre - complete	<i>Price:</i>
	<i>Weight:</i> 0,07 kg

### AC01 electronic unit connector (1 - 16) PIN – bottom



<b>Code: H0234</b> AC01 electronic unit connector (1 - 16) PIN – bottom	<i>Price:</i>
	<i>Weight:</i> 0,03 kg

### Connector with cabel



<b>Code: S0902</b> connector (NAC 52S.B) female with cabel	<i>Price:</i>
	<i>Weight:</i> 0,44 kg

### AC07 and AC07X electronic unit connector

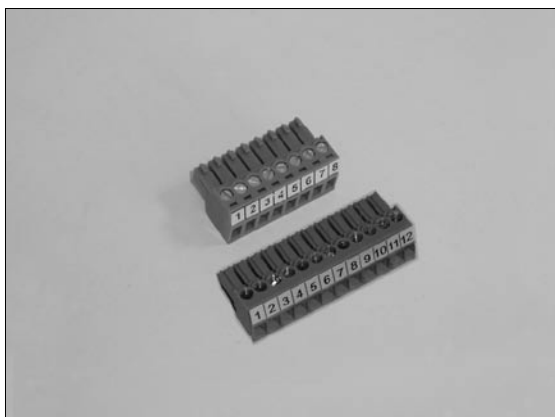

<b>Code: H0235</b> electronic unit connector (1 - 8) - top for unit AC07	<i>Price:</i>
	<i>Weight:</i> 0,01 kg
<b>Code: H0260</b> electronic unit connector (1 - 12) - top for unit AC07X	<i>Price:</i>
	<i>Weight:</i> 0,01 kg

### Connector

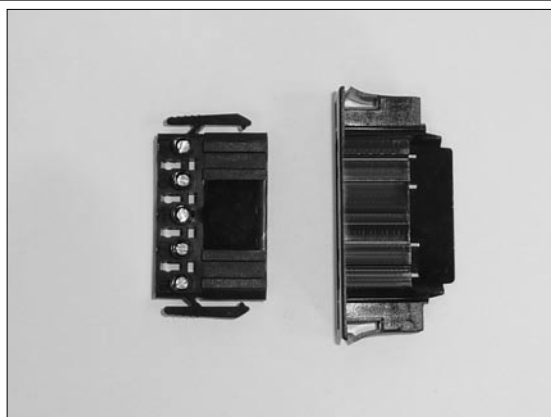

<b>Code: S0914</b> connector (NAC 51.B) – male with bushing	<i>Price:</i>
	<i>Weight:</i> 0,02 kg

### Suply burner connector with lid



**Code: S0991** connector - female for cabel  
- 6-pin - model 2012 (AC07X)

**Price:**  
**Weight:** 0,02 kg

### Konektor hořáku pro čidla s průchodkou



**Code: S0987** 6-pin connector with  
bushing - female - for sensors TSV,  
TK, TV and TS - for model 2012 with control unit AC07X

**Price:**  
**Weight:** 0,02 kg

### Burner connector with bushing



**Code: S0989** connector - male - 6-pin  
- model 2012 (AC07X)

**Price:**  
**Weight:** 0,02 kg

### Cleaning fire hook - small



**Code: V0346** fire hook for cleaning burning  
chamber of the burner A25 or A45 - small

**Price:**  
**Weight:** 0,12 kg

### Entrance connector for sensors with lid



**Code: S0988** 6-pin connector - male  
- for sensors TSV, TK, TV and TS  
- for model 2012 with control unit AC07X

**Price:**  
**Weight:** 0,02 kg

### Roof for conveyor DA a DRA

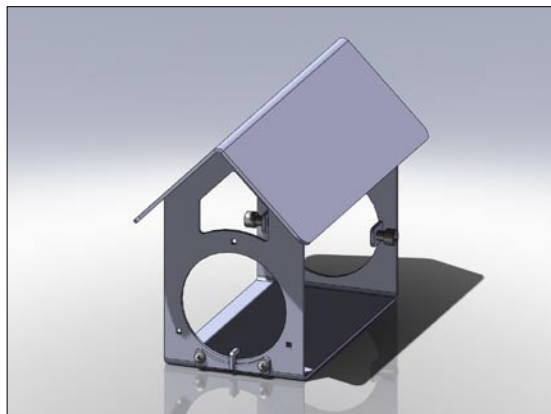

**Code: H0275** it is roof for conveyor in  
pellet silo with pellet level more than  
2 m

**Price:**  
**Weight:** 3,60 kg

## 7. Pellet burner IWABO



### Pellet burner IWABO



<b>Code: H0012</b> red color burner -(6 - 22 kW)	<i>Price:</i>
	<i>Weight:</i> 17,00 kg
<b>Code: H0013</b> grey color burner -(6 - 22 kW)	<i>Price:</i>
	<i>Weight:</i> 17,00 kg
<b>Code: H0022</b> pellet conveyer 1,5 m	<i>Price:</i>
	<i>Weight:</i> 10,00 kg
<b>Code: H0032</b> pellet conveyer 2,5 m	<i>Price:</i>
	<i>Weight:</i> 14,00 kg
<b>Code: H0060</b> fuse 6,3 A – into burner	<i>Price:</i>
	<i>Weight:</i> 0,01 kg
<b>Code: H0061</b> fuse 2 A – into burner	<i>Price:</i>
	<i>Weight:</i> 0,01 kg

### Photocell

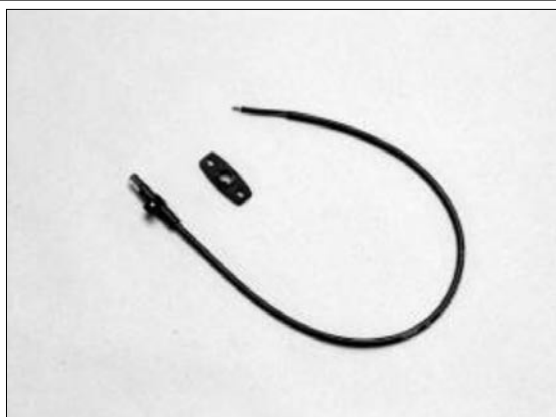

<b>Code: H0055</b> spare photocell - complete (H0231 + H0232)	<i>Price:</i>
	<i>Weight:</i> 0,07 kg

### Electronic unit PCB board IWABO

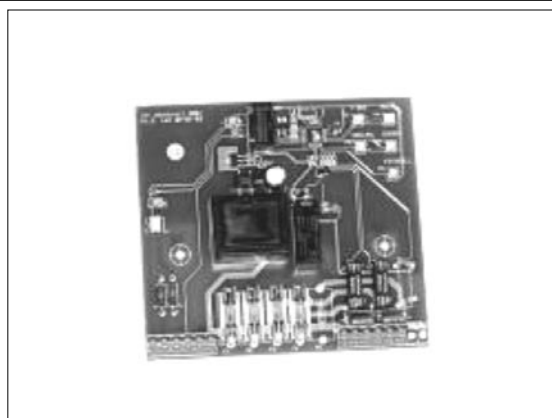

<b>Code: H0051</b> electronic unit PCB board – old version till prod no. 7899	<i>Price:</i>
	<i>Weight:</i> 0,20 kg
<b>Code: H0064</b> electronic unit PCB – new from no. 7900 to prod. no. 15809	<i>Price:</i>
	<i>Weight:</i> 0,28 kg
<b>Code: H0070</b> electronic unit PCB from prod no. 15810	<i>Price:</i>
	<i>Weight:</i> 0,28 kg

### Incoming feeding pipe

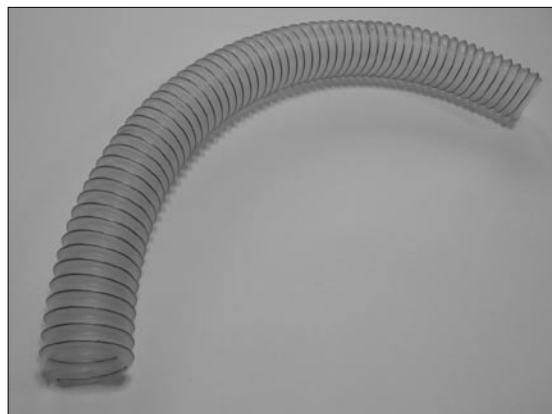

<b>Code: H0066</b> spare pipe between burner and pellet conveyor - lenght 1 m and Ø 65 mm - transparent	<i>Price:</i>
	<i>Weight:</i> 0,68 kg

### Heating spiral



<b>Code: H0052</b> heating spiral	<i>Price:</i>
	<i>Weight: 0,16 kg</i>
<b>Code: H0108</b> connection wires for ignition spiral IWABO	<i>Price:</i>
	<i>Weight: 0,04 kg</i>

### Blow fan

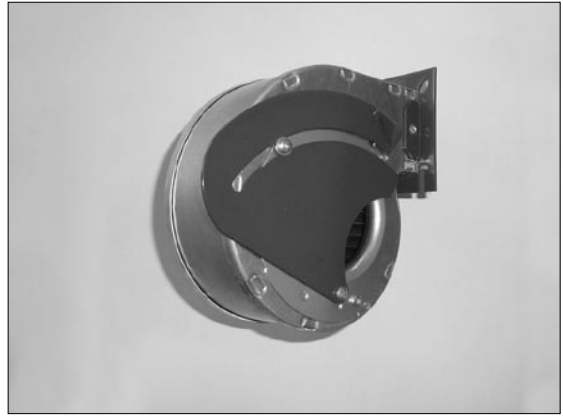

<b>Code: H0058</b> blower fan with speed sensor for burners with production number from 15810 - compensation for fan H0056	<i>Price:</i>
	<i>Weight: 1,12 kg</i>

### Combustion chamber (pot) of the burner

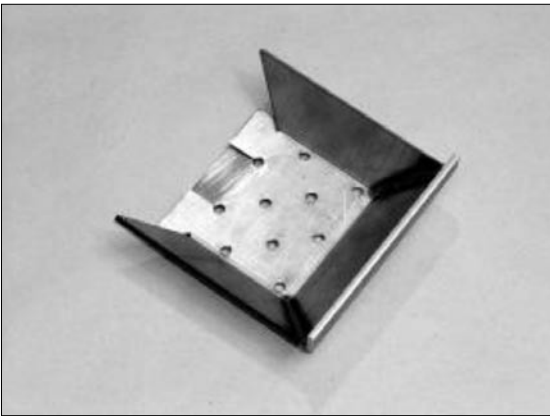

<b>Code: H0053</b> spare combustion chamber (pot) of the burner	<i>Price:</i>
	<i>Weight: 0,80 kg</i>

### Heating spiral cover

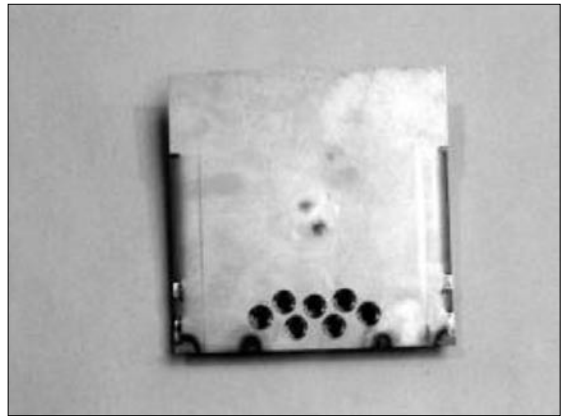

<b>Code: H0062</b> heating spiral cover	<i>Price:</i>
	<i>Weight: 0,78 kg</i>

### Safety thermostat 95°C



<b>Code: H0059</b> safety thermostat to burner supply pipe (two possible types) - can be changed	<i>Price:</i>
	<i>Weight: 0,02 kg</i>

### Gear box of the conveyor - old version



<b>Code: H0063</b> spare gear box 1,5 a 2,5 m - old	<i>Price:</i>
	<i>Weight: 2,10 kg</i>
<b>Code: H0105</b> spare gear box from production of the burner - 46985 - old version	<i>Price:</i>
	<i>Weight: 1,98 kg</i>

### Gear box of the conveyor– new version



**Code: H0107** gear box of the conveyor  
length 1,5 and 2,5 m - new version from  
2006 - axle diameter 10 mm

<i>Price:</i>
<i>Weight:</i> 2,72 kg

### L – part



**Code: S0454** for boilers D15P, D20P,  
DC15EP, DC18SP, DC25SP, DC32SP  
with pellet burner IWABO, as an backstop for end switch

<i>Price:</i>
<i>Weight:</i> 0,14 kg

### End-switch of the burner



**Code: H0065** end-switch of the burner

<i>Price:</i>
<i>Weight:</i> 0,34 kg

### Gear box housing



**Code: S0508** for standard delivered gear box  
with impeller - old version - metal version

<i>Price:</i>
<i>Weight:</i> kg

**Code: S0510** for new version of gear box  
– plastic version

<i>Price:</i>
<i>Weight:</i> kg

### Closing lid



**Code: S0509** intended for closing the air  
entrance when burning wood in boiler  
types DC15EP, DC18SP, DC25SP, DC32SP – for burners  
ATMOS A25 and IWABO VILLA S1

<i>Price:</i>
<i>Weight:</i> 0,20 kg

### Relay with varistor

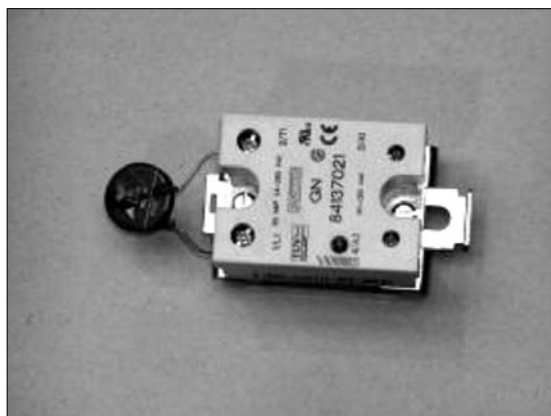

**Code: H0057** spare part for replacing all  
old relays (blue, white etc.) – for old  
versions of the PCB boards of IWABO burners

<i>Price:</i>
<i>Weight:</i> 0,02 kg

## 8. Pellet burner ERATO GP20



**Pellet burner ERATO GP20**



<b>Code: H0016</b> red burner output- (6-25 kW) - delivered with 2 m pellet conveyor, - included in the burner price	<i>Price:</i> <i>Weight:</i> 20,00 kg
--	--

**Power converter**



<b>Code: H0028</b> new type power converter unit - interchangeable with the old version	<i>Price:</i> <i>Weight:</i> 0,28 kg
--	---

**Electronic unit of the burner**



<b>Code: H0027</b> new version of the electronic unit - interchangeable with the old version	<i>Price:</i> <i>Weight:</i> 0,24 kg
---	---

**Incoming feeding pipe**

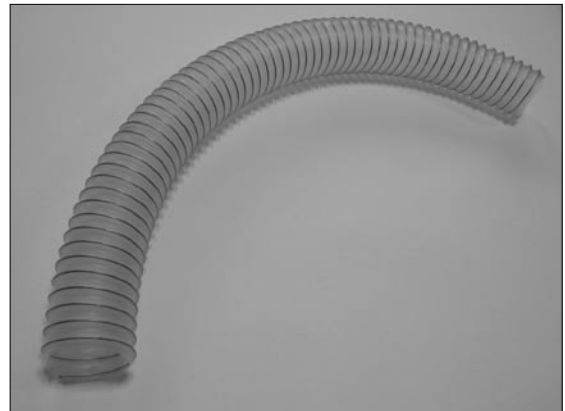

<b>Code: H0066</b> spare pipe between burner and pellet conveyor – lenght 1m - transparent	<i>Price:</i> <i>Weight:</i> 0,68 kg
--	---

### Heating spirale



**Code: H0020** spare heating spirale

*Price:*

*Weight:* 0,28 kg

### Photocell with a rubber ring - old



**Code: H0026** spare photocell - old

*Price:*

*Weight:* 0,15 kg

### Heating spiral cover

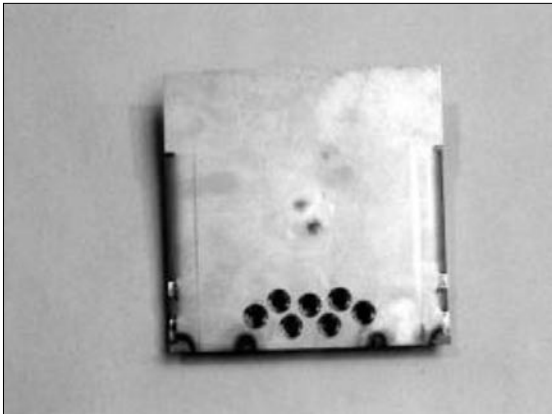

**Code: H0024** heating spiral cover

*Price:*

*Weight:* 0,78 kg

### Photocell - new



**Code: H0231** spare photocell

*Price:*

*Weight:* 0,05 kg

**Code: H0232** photocell holder

*Price:*

*Weight:* 0,02 kg

**Code: H0055** photocell with holdre  
- complete

*Price:*

*Weight:* 0,07 kg

### Combustion chamber (pot) of the burner

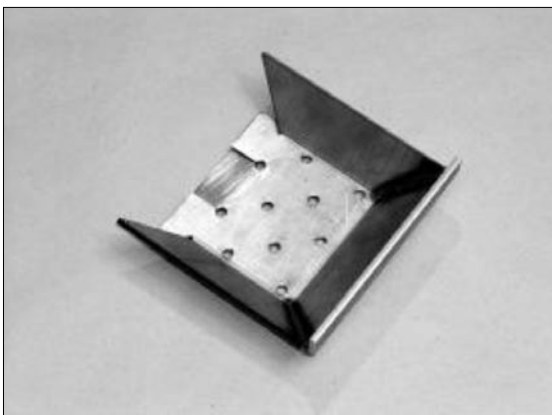

**Code: H0054** spare combustion (pot) of the  
burner

*Price:*

*Weight:* 0,78 kg

### Burner blower fan



**Code: H0031** spare burner blower fan

*Price:*

*Weight:* 1,44 kg



**Safety temperature thermostat – on the feeding pipe**



**Code: H0038** safety thermostat – on the feeding pipe – (2 types) – interchangeable with type H0059 – necessary to bent the connectors up!!!

*Price:*

*Weight: 0,03 kg*

**End-switch of the burner**



**Code: H0030** end-switch of the burner

*Price:*

*Weight: 0,34 kg*

**Gear box for conveyor – old version**



**Code: H0029** gear box for conveyor  
1,5 - 2 m

*Price:*

*Weight: 1,46 kg*

## 9. Pellet burner ATMOS A50



**Pellet burner ATMOS A50**



<b>Code: H0034</b> pellet burner - (13 - 48 kW)	<i>Price:</i>
	<i>Weight: 35,00 kg</i>
<b>Code: H0025</b> pellet conveyor without shaft DA50 - 1,7m	<i>Price:</i>
	<i>Weight: 16,50 kg</i>
<b>Code: H0039</b> pellet conveyor with shaft DRA50 - 1,7m	<i>Price:</i>
	<i>Weight: 17,00 kg</i>
<b>Code: H0037</b> pellet conveyor with shaft DRA50 - 2,5m	<i>Price:</i>
	<i>Weight: 23,00 kg</i>
<b>Code: H0188</b> spare bearing for conveyors DA50, DRA50	<i>Price:</i>
	<i>Weight: 0,22 kg</i>

**Elektronic unit PCB board**



<b>Code: H0131</b> new elektronic unit PCB board	<i>Price:</i>
	<i>Weight: 1,58 kg</i>

**Photocell**



<b>Code: H0130</b> spare photocell	<i>Price:</i>
	<i>Weight: 0,02 kg</i>

**Incoming feeding pipe**



<b>Code: H0196</b> spare pipe between burner and pellet conveyor - lenght 1 m and Ø 73 mm - untransparent	<i>Price:</i>
	<i>Weight: 0,68 kg</i>

**Pot – combustion chamber**

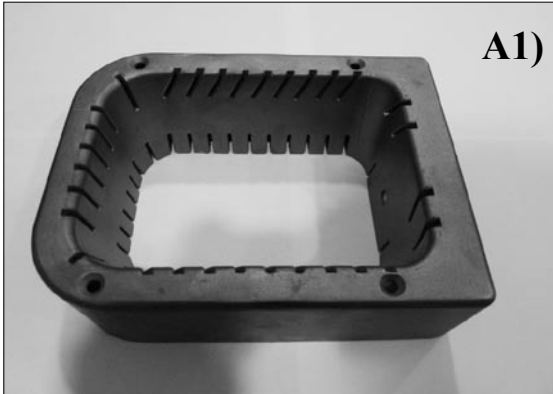

**A1)**



**A2)**

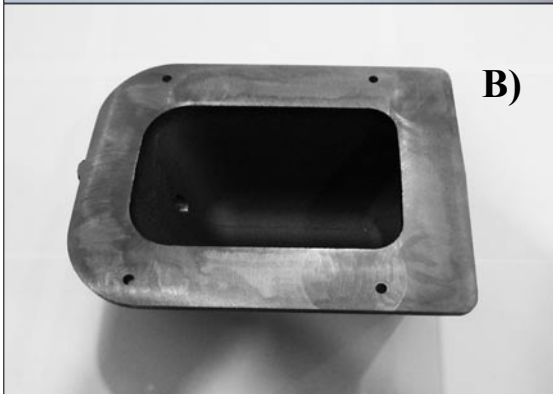

**B)**

<b>Code: H0149</b> A) combustion chamber - upper part	<i>Price:</i>
	<i>Weight: 4,24 kg</i>
<b>Code: H0149</b> A) combustion chamber - upper part - ATMOS	<i>Price:</i>
	<i>Weight: 4,86 kg</i>
<b>Code: H0150</b> B) combustion chamber - lower part	<i>Price:</i>
	<i>Weight: 3,80 kg</i>

**Ignition spiral**



<b>Code: H0128</b> spare ignition spiral	<i>Price:</i>
	<i>Weight: 0,20 kg</i>

**Primary air blower fan – without crosshatch**



<b>Code: H0126</b> primary air blower fan – without crosshatch	<i>Price:</i>
	<i>Weight: 1,50 kg</i>

**Secondary air blower fan – with crosshatch**



<b>Code: H0125</b> secondary air blower fan – with crosshatch	<i>Price:</i>
	<i>Weight: 1,38 kg</i>

**Incoming module AC05**



<b>Code: S0076</b> incoming module AC05 set for controlling the burner from the boiler regulating thermostat	<i>Price:</i>
	<i>Weight: 0,07 kg</i>

### Optical sensor for measuring of pellet level

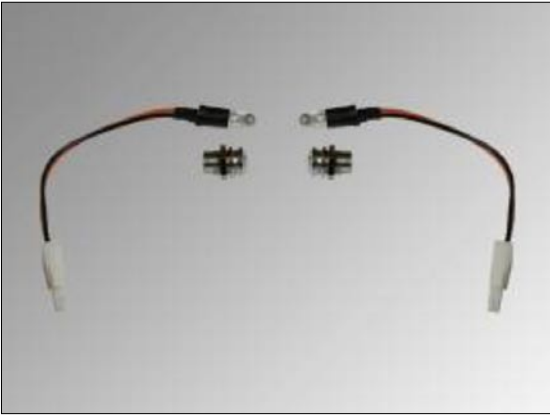

**Code: H0129** optical sensor for pellet level  
– 2pcs

<i>Price:</i>
<i>Weight:</i> 0,02 kg

### Data cabel for sensors



**Code: H0144** data cabel for sensorsy

<i>Price:</i>
<i>Weight:</i> 0,10 kg

### Waste gas sensor



**Code: H0141** saste gas sensor

<i>Price:</i>
<i>Weight:</i> 0,08 kg

### Adapter from connector to connector Faston



**Code: H0145** adaption from connector to connector Faston

<i>Price:</i>
<i>Weight:</i> 0,03 kg

### Incoming cable into burner



**Code: H0143** incoming cable into burner

<i>Price:</i>
<i>Weight:</i> 0,45 kg

### Jumper for extra safety thermostat



**Code: H0146** jumper for extra safety thermostat (brown/white wire)

<i>Price:</i>
<i>Weight:</i> 0,07 kg

### Extension cable for for waste gas sensor



<b>Code: H0147</b> extension cable for waste gas sensor with lenght – 1,8 m	<i>Price:</i>
	<i>Weight: 0,25 kg</i>
<b>Code: H0148</b> extension cable for waste gas sensor with lenght – 1 m	<i>Price:</i>
	<i>Weight: 0,20 kg</i>

### Cog wheels



<b>Code: H0133</b> cg wheel with 12 cogs – inner auger – turnstile	<i>Price:</i>
	<i>Weight: 0,30 kg</i>
<b>Code: H0134</b> cog wheel with 17 cogs – for motor gera box	<i>Price:</i>
	<i>Weight: 0,35 kg</i>
<b>Code: H0135</b> cog wheel with 18 cogs – main auger of the combustion chamber	<i>Price:</i>
	<i>Weight: 0,35 kg</i>
<b>Code: H0136</b> cog wheel with 24 cogs – upper filling auger	<i>Price:</i>
	<i>Weight: 0,40 kg</i>

### Slide bearing



<b>Code: H0138</b> set of slide bearing ( 6 pcs ) – 3 types	<i>Price:</i>
	<i>Weight: 0,09 kg</i>

### Chain with clip



<b>Code: H0137</b> chain with clip	<i>Price:</i>
	<i>Weight: 0,32 kg</i>

### Inner blades of the turnstile

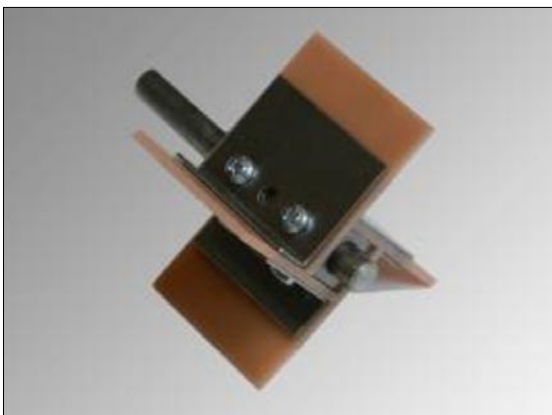

<b>Code: H0132</b> inner blades of the turnstile – shaft with blades	<i>Price:</i>
	<i>Weight: 0,18 kg</i>

### Gear Box



<b>Code: H0127</b> spare gear box with electric capacitor	<i>Price:</i>
	<i>Weight: 3,54 kg</i>
<b>Code: H0152</b> spare electric capacitor 2 $\mu$ F for gear box	<i>Price:</i>
	<i>Weight: 0,02 kg</i>

### Gear box for pellet conveyor type DA



<b>Code: H0186</b> gear box for pellet conveyor DA length 1,7m and for 2,5m. Diameter of the shaft - 10 mm Attention – if changing the red one by the grey one you have to change the running direction in the motor of the gear box after the electric diagram of the motor.	<i>Price:</i>
	<i>Weight: 3,50 kg</i>

### Spare gear box for conveyor DA – 40W



<b>Code: H0159</b> spare gear box for pellets conveyor DA50 1,7m a 2,5m with input 40W. Diameter of the shaft - 12 mm.	<i>Price:</i>
	<i>Weight: 4,50 kg</i>

### Module DPA70 for prolonging of running of the suction fan



<b>Code: H0184</b> spare module DPA70 for pro- longing of running of the suction fan - 5 pin	<i>Price:</i>
	<i>Weight: 0,40 kg</i>
<b>Code: H0185</b> spare module DPA70 for pro- longing of running of the suction fan - 4 pin	<i>Price:</i>
	<i>Weight: 0,40 kg</i>

## 10. Automatic ash removal for boilers DxxP



### Parts for fitting automatic ash removal

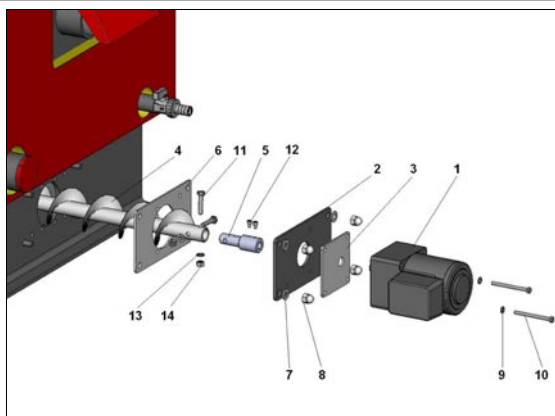

<b>Code: S0577</b> ash cleaner/remover – without ash pan for boilers D14P, D21P	<i>Price:</i>
	<i>Weight:</i> 11,06 kg
<b>Code: S0578</b> ash cleaner/remover – without ash pan for boiler D25P	<i>Price:</i>
	<i>Weight:</i> 11,62 kg
<b>Code: S0535</b> ash cleaner/remover – without ash pan for boilers D15P, D20P	<i>Price:</i>
	<i>Weight:</i> 13,34 kg
<b>Code: S0536</b> ash cleaner/remover – without ash pan for boiler D30P	<i>Price:</i>
	<i>Weight:</i> 17,54 kg
<b>Code: S0537</b> ash cleaner/remover – without ash pan for boiler D45P	<i>Price:</i>
	<i>Weight:</i> 17,88 kg
<b>Code: S0125</b> position 6. sealing of the gear box flange	<i>Price:</i>
	<i>Weight:</i> 0,01 kg
<b>Code: S0126</b> position 3. gear box sealing	<i>Price:</i>
	<i>Weight:</i> 0,01 kg
<b>Code: H0107</b> position 1. gear box 25W	<i>Price:</i>
	<i>Weight:</i> 2,72 kg
<b>Code: S0077</b> elektronik module AD01 for automatic ash removal timing	<i>Price:</i>
	<i>Weight:</i> 0,18 kg
<b>Code: S0538</b> position 4. auger shaft – lenght 530 mm for boilers D15P, D20P	<i>Price:</i>
	<i>Weight:</i> 1,36 kg
<b>Code: S0539</b> position 4. auger shaft – lenght 730 mm for boilers D30P	<i>Price:</i>
	<i>Weight:</i> 1,94 kg
<b>Code: S0540</b> position 4. auger shaft – lenght 930 mm for boilers D45P	<i>Price:</i>
	<i>Weight:</i> 2,36 kg

### Parts for fitting ashtray flange

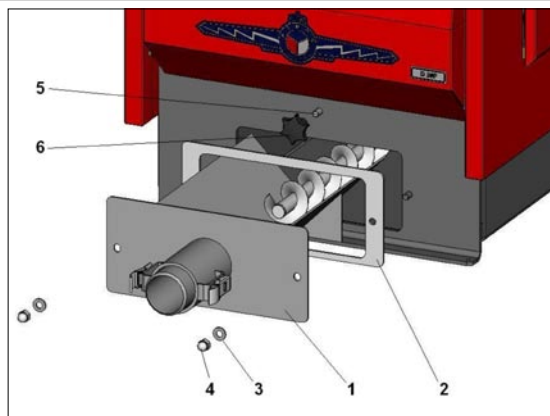

<b>Code: S0128</b> position 2 sealing of the automatic ash removal flange	<i>Price:</i>
	<i>Weight:</i> 0,03 kg
<b>Code: S0411</b> position 6 - plastic nut for sealing the hole after grate pull	<i>Price:</i>
	<i>Weight:</i> 0,06 kg
<b>Code: S0542</b> ash-pan volume 28 Lt.	<i>Price:</i>
	<i>Weight:</i> 7,70 kg
<b>Code: S0544</b> ash-pan volume 68 Lt.	<i>Price:</i>
	<i>Weight:</i> 11,90 kg
<b>Code: S0546</b> ash-pan volume 135 Lt.	<i>Price:</i>
	<i>Weight:</i> 18,46 kg
<b>Code: S0280</b> sealing sticking tape for ash-pan volume 28 and 68 Lt.	<i>Price:</i>
	<i>Weight:</i> 0,06 kg
<b>Code: S0288</b> sealing sticking tape for ash-pan volume 135 Lt.	<i>Price:</i>
	<i>Weight:</i> 0,03 kg
<b>Code: S0549</b> O - ring - sealing flange ashtray	<i>Price:</i>
	<i>Weight:</i> 0,02 kg

## 11. LFO and Natural gas burners

### LFO or natural gas burner



<b>Code: H0018</b> LFO burner – Riello 40G3RK	<i>Price:</i>
	<i>Weight:</i> 11,34 kg
<b>Code: H0017</b> natural gas burner – Riello 40GS+MDB055	<i>Price:</i>
	<i>Weight:</i> 12,62 kg
<b>Code: H0019</b> connecting cable for LFO burner – not delivered with burner	<i>Price:</i>
	<i>Weight:</i> 0,06 kg

### Spare parts + accessories:

Title	Code	Price	Weight
<b>Spare parts for natural gas burner Riello 40G S 3 code 3755116 – 3755117 type 551 T1</b>			
Automatic unit 525 SE/5	H0073		0,48 kg
Air manostat	H0074		0,24 kg
Ignition coil	H0075		0,05 kg
Ionized electrode	H0076		0,03 kg
Elektromotor (same for G+C38RK)	H0077		2,70 kg
<b>Spare parts for oil burner Riello 40G 3 RK code 3743412 type 434 T1</b>			
Automatika 531 SE	H0078		0,44 kg
Light resistor	H0079		0,02 kg
Capacitor 4 µF	H0080		0,08 kg
Tenon	H0081		0,01 kg
Pump	H0082		1,09 kg
Pump sealing	H0083		0,03 kg
Pump filter	H0084		0,01 kg
Ventil	H0085		0,03 kg
Coil	H0086		0,06 kg
Electrode	H0087		0,18 kg
Heating resistor	H0088		0,03 kg
<b>Accessories</b>			
Oil filter / automatic air-bleeding valve – TOC80	H0089		0,01 kg
Connector 8	H0090		0,09 kg
Conector 10	H0091		0,02 kg
Nozzle Delavan - 40/60/W – (15kW)	H0092		0,02 kg
Nozzle Delavan – 0,50/60/W – (20kW)	H0093		0,02 kg
Nozzle Delavan – 0,60/60/W – (25kW)	H0094		0,03 kg
Nozzle Delavan – 0,65/60/W – (30kW)	H0095		0,03 kg
Nozzle Delavan – 0,75/60/B – (35kW)	H0096		0,03 kg
ProTek valve	H0097		0,07 kg