

OPERATING AND INSTALLATION MANUAL

ELECTRIC WATER HEATER

TO 5.1 UP/IN
TO 10.1 UP/IN



Družstevní závody Dražice-strojírna s.r.o.
Dražice 69, 294 71 Benátky nad Jizerou
tel.: +420 / 326 370 911
fax: +420 / 326 370 980
e-mail: export@dzd.cz

 **DRAŽICE**
MEMBER OF THE NIBE GROUP

CONTETNT

1	PRODUCT ACCESSORIES	4
2	MESSAGE FOR CUSTOMERS	4
3	TECHNICAL DESCRIPTION	4
4	GENERAL TECHNICAL DATA.....	5
5	OPERATING ACTIVITY	5
6	WALL MOUNTING.....	5
7	PLUMBING FIXTURE.....	6
8	ELECTRIC INSTALLATION.....	8
9	HEATER COMMISSIONING.....	8
10	IMPORTANT NOTICE.....	9
10.1	DISPOSAL OF PACKAGING MATERIAL AND FUNCTIONLESS PRODUCT	9
11	FUNCTIONAL DEFECTS.....	10
12	FIRE-FIGHTING REGULATIONS FOR INSTALLATION AND USE OF HEATER.....	10
13	USE AND MAINTENANCE OF HEATER.....	11
14	INSTALLATION REGULATIONS.....	11
15	FRONT PANEL	12
16	FIGURE	13
16.1	HEATER DIMENSIONS	13
16.2	WIRING SCHEME.....	14

CAREFULLY READ THIS MANUAL BEFORE INSTALLING THE WATER HEATER!

Dear Customer,

Družstevní závody Dražice - strojírna s.r.o., would like to thank you for your decision to use a product of our brand. With this guide, we will introduce you to the use, construction, maintenance, and other information on electrical water heaters.



The product is not intended to be controlled by

- a) people (including children) with reduced physical, sensual, or mental capacities, or
- b) people with insufficient knowledge and experiences unless supervised by responsible person, or unless properly instructed by such responsible person.

The manufacturer reserves the right for engineering modification of the product. The product is designed for permanent contact with drinkable water.

It is recommended to use the product in indoor environment with air temperatures from +2 °C to +45 °C and a relative humidity up to 80 %.

Product's reliability and safety is proven by tests implemented by the Engineering Test Institute in Brno.

Made in the Czech Republic.



To ensure proper functioning, the water heater must be connected to a permanent power supply. The electrical installation may only be carried out by a person authorized to install devices in the electrical area (does not apply to inserting the plug into the socket).

Meaning of pictograms used in the Manual



Important information for heater users.



Abiding by the recommendations of the manufacturer serves to ensure trouble-free operation and the long service life of the product.



**Caution!
Important notice to be observed.**

1 PRODUCT ACCESSORIES

The product is packed together with service instructions. The heater is equipped with a safety valve as a protective element. The valve is mounted on the cold water supply (see chapter 7)

2 MESSAGE FOR CUSTOMERS

The water temperature is set by a thermostat to 55 °C. The electrical heater is designed for preparation of hot water in households, cottages and various welfare facilities. It allows the installation of only one hot water draw-off point with a pressure-free connection. In case of a pressure connection, it is possible to connect more sampling points, but with limited use of simultaneous sampling. Its benefit is that it heats up water by power in an unlimited all-day time range, due to small accumulation, the connection with HDO signal control is not recommended. The time of heating service water is about 9 and 18 minutes, depending on the volume.

3 TECHNICAL DESCRIPTION

The heater tank is steel enameled for pressure connection, the electrical heating element is of an immersion type. The heater tank consists of magnesium anode that helps protect the heater tank from corrosion. The heater tank is provided with polyurethane insulation and everything is stored in a plastic cover. The electrical wiring is placed in the bottom (upper) part of the heater, under the removable cover of the heater. The water temperature is set by a thermostat to 55 °C. The cold water inflow is indicated with a blue ring, hot water outflow is indicated with a red ring.

TO 5.1, 10.1 **UP** - pressure heater with a capacity of 4.6 and 9.6 liters located above the consumption point

TO 5.1, 10.1 **IN** - pressure heater with a capacity of 4.6 and 9.6 liters located under the consumption point



The TO 5.1, 10.1 IN/UP heaters can also be used as non-pressure heaters.

4 GENERAL TECHNICAL DATA

		TO 5.1 IN/UP	TO 10.1 IN/UP
VOLUME	l	4.6	9.6
RATED PRESSURE	bar	6	6
ELECTRIC CONNECTION	1 PE-N 230V/50HZ		
RECOMMENDED BREAKER	16 A		
INPUT	W	1500	
EL. PROTECTION	IP X5		
MAX. WEIGHT OF THE HEATER WITHOUT WATER (WITH WATER)	kg	6.0 (10.6)	8.0 (17.6)
TIME OF EL. HEATING FROM 10 °C TO 60 °C	min	13	25
MIXED WATER V40	l	4.06 / 5.51	11.2 / 13.38
LOAD PROFILE	XXS		XXS
ENERGY EFFICIENCY CLASS	A		A
ENERGY EFFICIENCY	%	36.24 / 37.10	35.17 / 35.12
ANNUAL CONSUMPTION OF ELECTRIC ENERGY	kWh	509 / 497	525

Table 1

5 OPERATING ACTIVITY

After connecting the heater to the mains, the immersion heater heats up the water. The element is turned on and off by a thermostat. After reaching the temperature set, the thermostat switches off the electrical circuit and discontinues water heating. The heat control light signals if the element is in operation (the light is on) or if it is off (the light goes out).

6 WALL MOUNTING

Prior to mounting check the loading capacity of the wall. If needed, reinforce it. Mount the water heater in vertical position only. The fastening screws must have guaranteed spacing of 140 mm. The mounting dimensions are specified in Fig. 3.

7 PLUMBING FIXTURE

Water inflow and outflow is indicated with different color terminals on the heater tubes. Cold water supply is indicated with blue and hot water outflow is indicated with red. There are two ways of connecting the water heater to water network. Closed, pressure connection system allows water withdrawal at multiple supply (withdrawal) points whilst open flow system allows one supply (withdrawal) point only. With regard to the selected way of connection, you need to purchase suitable combination faucets.

For the open flow system, you need to mount a return valve in order to avoid water outflow from the boiler if water supply gets discontinued. For this type of connection, you have to use the flow combination faucet. Due to heating, the volume of water increases, which causes water dripping from the combination faucet pipe. You will not prevent water from dripping by strong tightening of the combination faucet valve, but you may damage the combination faucet.

For the closed pressure connection system, you need to use pressurized combination faucets at the withdrawal points. You have to attach a safety valve to the filling pipe to avoid increase of pressure in the tank above the rated pressure. During water heating in the heater, the water pressure in the tank increases until it reaches the limit set on the safety valve.

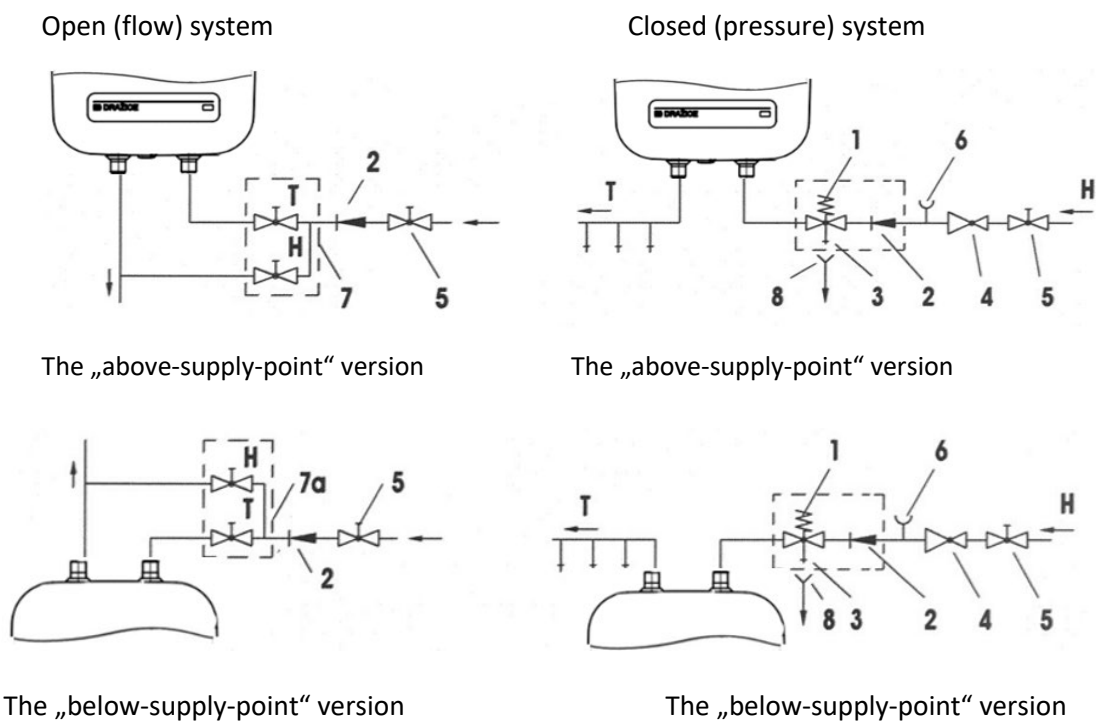

Figure 1

Explanation:

- 1 - Safety valve
- 2 - Back pressure valve
- 3 - Test valve
- 4 - Reduction valve
- 5 - Shut-off valve
- 6 - Test adaptor
- 7, 7a - Flow combination faucet
- 8 - Funnel with connector to drain from the safety valve
- H - Cold water
- T - Hot water

Safety valve is mounted on the cold water inlet identified with a blue ring. Each hot service water pressure heater must have a safety valve with a membrane spring. Nominal clearance of safety valves is defined in the ČSN 06 0830 standard. The safety valve must be well accessible, as near to the heater as possible. The input pipes must have at least the same clearance as the safety valve. The safety valve is placed high enough to secure dripping water drain by gravity. We recommend mounting the safety valve onto a branch pipe. This allows easier exchange without having to drain the water from the heater. Safety valves with fixed pressure settings from the manufacturer are used for the assembly. Starting pressure of a safety valve must be identical to the maximum allowed heater pressure, and at least 20 % higher than the maximum pressure in the water main. If the water main pressure exceeds such value, a reduction valve must be added to the system.



No stop valves can be put between the heater and the safety valve.

During the assembly, follow the guide provided by the safety equipment manufacturer. It is necessary to check the safety valve each time before putting it into operation. It is checked by manual moving of the membrane from the seat, turning the make-and-break device button always in the direction of the arrow. After being turned, the button must click back into a notch. Proper function of the make-and-break device results in water draining through the safety valve outlet pipe. In common operation, such a check needs to be implemented at least once a month, and after each heater shutdown for more than 5 days. Water may be dripping off the drain pipe of the safety valve; the pipe must be open into the air, pointed down; environment temperatures must not drop below zero. When draining the heater, use a recommended draining valve. First, close water input into the heater

Find necessary pressure values in the following table - Table 2.

SAFETY VALVE STARTING PRESSURE [MPa]	ADMISSIBLE OPERATING WATER HEATER PRESSURE [MPa]	MAX PRESSURE IN THE COLD WATER PIPE [MPa]
0.6	0.6	up to 0.48

Table 2

For proper safety valve operation, a backflow valve must be mounted on the inlet pipes, preventing spontaneous heater draining and hot water penetrating back into the water main.



We recommend that the hot water distribution from the heater was as short as possible to minimize heat losses.

Heaters TO UP must be provided with a discharge valve mounted on the cold service water inlet to the heater for potential disassembly or repair.



When assembling the security equipment, follow the standard.

8 ELECTRIC INSTALLATION

The electrical wiring scheme is attached in the manual to the water heater (Figure 4). The heater must be connected via a separate supply with a circuit breaker. The heater is connected to the 230V/50Hz mains with a power cable by inserting the plug into the socket. The electrical installation must comply with valid electrical and technical standards. The connection of the heater to the electrical network is made after the water supply installation of the heater and the filling of the heater with water.

Follow the rules of protection against electrical injuries in accordance with standard CSN 33 2000 - 4 - 41.

The degree of protection of the electrical parts of the heater is IP X5.

9 HEATER COMMISSIONING

After connecting the heater to the water supply network, the heater can be put into operation.

Procedure:

- a) check the electric and water main installation
- b) open the hot water valve on the combination faucet
- c) open the cold water inlet valve to the heater
- d) as soon as the water starts running through the hot water valve, the heater is filled and the valve closes
- e) using the front-end main switch open electricity and thus the heater activates



Before first use, or after longer periods, it is necessary to ensure flushing, irrigation and ventilation heater before starting the heating. The first heating tank must be monitored.

10 IMPORTANT NOTICE



- Without a confirmation issued by an authorized company about performed electrical and plumbing fixture the warranty certificate shall be void.
- The hot water outlet must be equipped with a combination faucet.
- It is not allowed to handle the thermostat in any manner whatsoever, aside from temperature resetting with a control button.
- All electric installation handling, adjustment and replacement of the regulation elements shall only be performed by an authorized service company.
- **The thermal fuse must not be turned off!** The non-reversible thermal fuse discontinues electric power input to the heating element should the thermostat fail, if the water temperature in the heater exceeds 99 °C.

If the water heater is mounted in enclosed areas, inter-ceilings, built-in structures, and recesses, ensure sufficient access to service fittings, electrical terminal boards, anodes and manholes. Minimum spacing from manhole is 200 mm.

10.1 DISPOSAL OF PACKAGING MATERIAL AND FUNCTIONLESS PRODUCT

A service fee for providing return and recovery of packaging material has been paid for the packaging in which the water heater was delivered. Was paid pursuant to Act No. 477/2001 Coll., as amended, at EKO-KOM a.s. The client number of the company is F06020274. Take the product packages to a waste disposal place designated to that purpose by the municipality. When the operation terminates, disassemble, and transport the discarded and unserviceable heater to a waste recycling center (collecting yard), or contact the manufacturer.



11 FUNCTIONAL DEFECTS

DEFECT	FAILURE	
Water in the tank is cold	<ul style="list-style-type: none"> • LED is on 	<ul style="list-style-type: none"> • heating element failure
Water in the tank is not warm enough	<ul style="list-style-type: none"> • LED is on 	<ul style="list-style-type: none"> • heating element failure
Water in the tank is cold	<ul style="list-style-type: none"> • LED is not on 	<ul style="list-style-type: none"> • operating thermostat failure - safety thermostat shut off power supply • power supply outside the heater discontinued
Water temperature in the tank does not correspond with value set		<ul style="list-style-type: none"> • thermostat failure

Table 3



Do not attempt to repair the faults yourselves. Contact either a professional or service center. It does not take much for a professional to remove the fault. **When arranging a repair appointment, state the type and serial number you find on the rating plate of your water heater.**

12 FIRE-FIGHTING REGULATIONS FOR INSTALLATION AND USE OF HEATER



We would like to emphasize that the heater must not be connected to power supply if work involving flammable liquids (petrol, spot remover) or gases, etc., is performed nearby.

13 USE AND MAINTENANCE OF HEATER

Once connected to the water and electrical network, the heater is ready for use.

The operation of the electrical heater is indicated by a signal light that goes on until the water in the heater is heated

to the set temperature. As a result of the heating, the volume of water increases, which causes the water to drip from the safety valve.

If you do not intend to use the heater constantly, you need to protect the water in the heater by not discontinuing the power totally. If you take the heater off the power supply, you have to drain the water from it if there is a risk that the water inside freezes. Empty the heater.

Clean the outer parts of the appliance with a mild detergent solution. Do not use thinners or other concentrated cleaning agents. Regular service inspections will ensure trouble-free operation and a long service life of the heater.

By repeatedly heating the water, lime scale settles on the walls of the tank. Lime scale settling depends on the hardness of the heated water, its temperature and on the volume of hot water consumed.



We recommend that the first inspection of the heater is carried out by a specialist, approximately two years after connection.

During the inspection the scale, that accumulates inside the heater depending on the quality, amount and temperature of the water consumed, will be removed as needed. The service will recommend the date of the next inspection when inspecting the radiator and taking into account the detected



CAUTION: Prior to any intervention inside the heater, the device must be disconnected from the mains!



Do not attempt to repair the heater by yourselves, call the nearest authorized service center to do so.

14 INSTALLATION REGULATIONS



Both the electric and water installation must follow and meet the requirements and regulations relevant in the country of use!

15 FRONT PANEL

There is a symbol for the signal light of the heater operation.



Figure 2

	NAME	FUNCTION DESCRIPTION
1	Signal light	Indication of active heating

Table 4



The front panel is equipped with a protective foil which must be removed for proper readability of the panel.

16 FIGURE

16.1 HEATER DIMENSIONS

The „abow-supply-point“ version

The „below-supply-point“ version

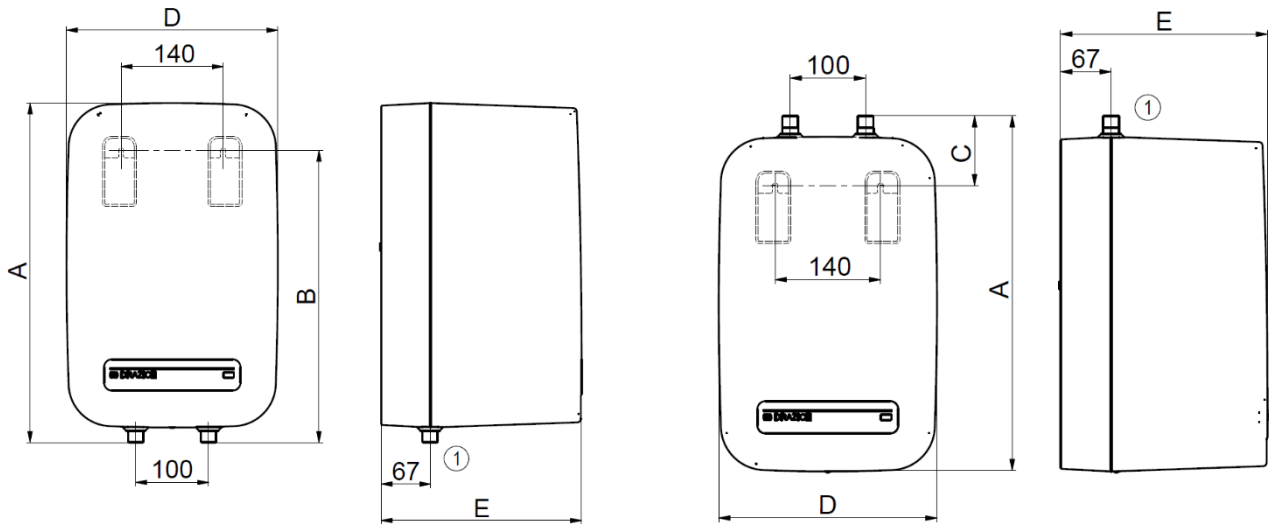

Figure 3

	A [mm]	B [mm]	C [mm]	D [mm]	E [mm]
TO 5.1 UP	330	265	-	290	275
TO 5.1 IN	338	-	93	290	275
TO 10.1 UP	465	400	-	290	275
TO 10.1 IN	473	-	93	290	275

①	1/2" outer
---	------------

Table 5

16.2 WIRING SCHEME

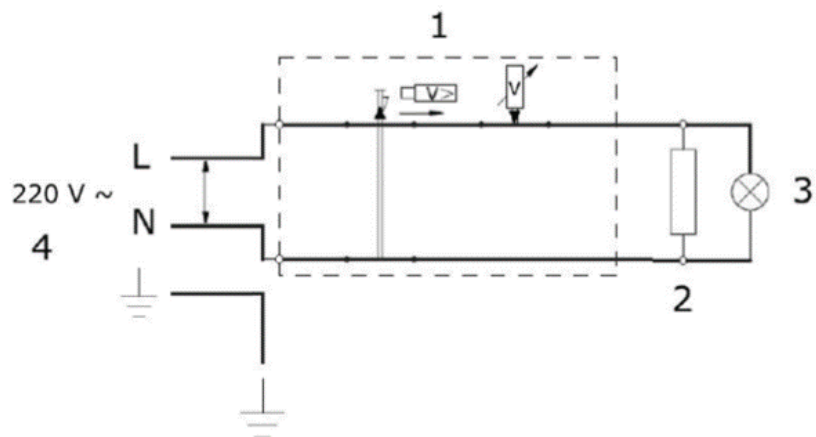

Key:

- 1 - thermostat and reversible thermal fuse
- 2 - Heating element
- 3 - Operation indicator
- 4 - Power supply

Figure 4

13-7-2020