

TACOFLOW3 MAX

HEATING AND COOLING CIRCUIT PUMPS



Glandless circulator pumps for hot water heating systems in residential and commercial buildings.

DESCRIPTION

The TacoFlow3 MAX is driven by permanent-magnet synchronous motors.

These innovative motors achieve a high efficiency at low operating costs.

They are maintenance-free and do not need replacement of seals and gaskets.

INSTALLATION POSITION

The pump can be installed both horizontally or vertically.

The arrow indicating the medium's flow direction must be observed.

ADVANTAGES

- activeADAPT function: Automatic adaptation of the pump rate to the specific requirements of the system
- Efficient output setting with variable Δp -v proportional pressure curve, constant pressure curves Δp -c, fixed min./max. speed and 0-10 V or PWM control
- Media temperature range from -10°C to $+110^{\circ}\text{C}$
- Insulation shell supplied as standard
- A colour LED indicates the current operating state

OPERATION

The circulation pump are of a glandless design, since the rotating parts of the motor run inside the pumped medium. This provides lubrication for the motor and the rotating parts. The circulation pump is equipped with anti-blocking protection, since the high efficiency pumps no longer have a pump head screw for manual unblocking. They also feature an automatic venting function, which detects and indicates any air in the pump.

BUILDING CATEGORIES

- Apartment blocks, multiple dwelling units
- Public buildings
- Hotels and restaurants, industrial kitchens
- School buildings and sports facilities
- Office, commercial and industrial buildings
- Facilities with partial use, such as barracks, camping sites

SYSTEM/BASIC DIAGRAM

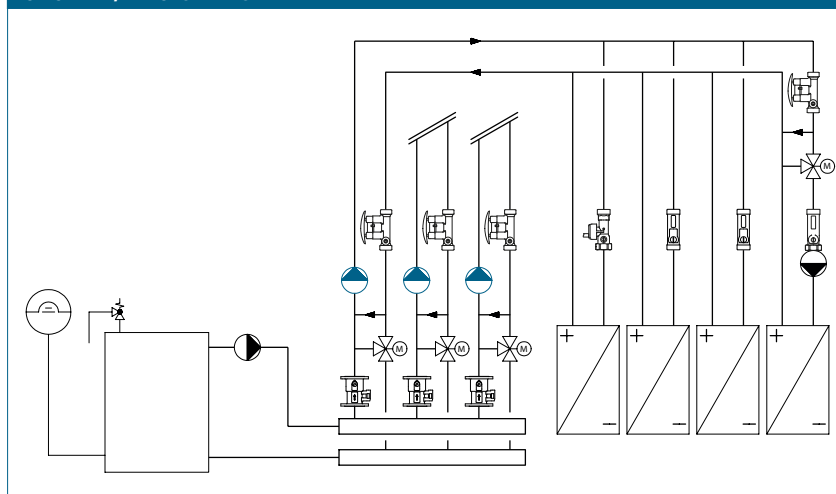

TACOFLOW3 MAX | HEATING AND COOLING CIRCUIT PUMPS

SPECIFICATION TEXT

See www.taconova.com

TECHNICAL DATA

Pump

- Ambient temperature: +0 °C to +40 °C
- Permissible temperature range: -10 °C to +110 °C
- Permissible temperature ranges at max. ambient temperature:
 - at 30 °C: +30 °C to +100 °C
 - at 40 °C: +40 °C to +70 °C
- Static pressure: Max. 1.0 MPa - 10 bar
- Minimum pressure at air intake:
 - 0.05 MPa (0.5 bar) at 80 °C
 - 0.15 MPa (1.5 bar) at 95 °C
- Max. relative humidity: ≤ 80%
- Sound pressure level: < 43 dB (A)
- Low Voltage Directive (2006/95/EC): Standards applied: EN 60335-1 and EN 60335-2-51
- EMC Directive (2004/108/EC); Standards applied: EN 61000-3-2, EN 61000-3-3
- Ecodesign Directive (2009/125/EC); Standards applied: EN 16297-1, EN 16297-2
- Inputs/outputs: PWM, 0-10 VDC

Material

- Pump body: Cast iron, CDP-coated (EN-GJL-200)
- Impeller: Brass / Composite plastic
- Shaft: Ceramic
- Bearing: Graphite / Ceramic
- Rotor housing: Composite plastic

TECHNICAL DATA (CONTINUED)

Motor and electronics

- Supply voltage: 1x230 V (±10%), PE frequency: 50/60 Hz
- Power rating (P1): Min. 16 W, max. 88 W
- Rated current (I1): Min. 0.2 A, max. 0.6 A
- Insulation class: F
- Protection rating: IP 44
- Temperature class: TF 110

TYPE OVERVIEW

TacoFlow3 MAX | Heating and cooling circuit pumps
 Cast iron high efficiency pump with threaded and plug connection.
 Standard thermal insulation shell.
 Pump head: 6 m

TECHNICAL DATA (CONTINUED)

Fluids

- Heating water (VDI 2035; SWKI BT 102-01; ÖNORM H 5195-1)
- Water and proprietary additives used against corrosion and freezing up to 30 %

Order no.	Designation	G	Centre distance	Weight
302.5238.000	MAX 25-60/180	1 ½"	180 mm	3.5 kg
302.6238.000	MAX 32-60/180	2"	180 mm	3.5 kg

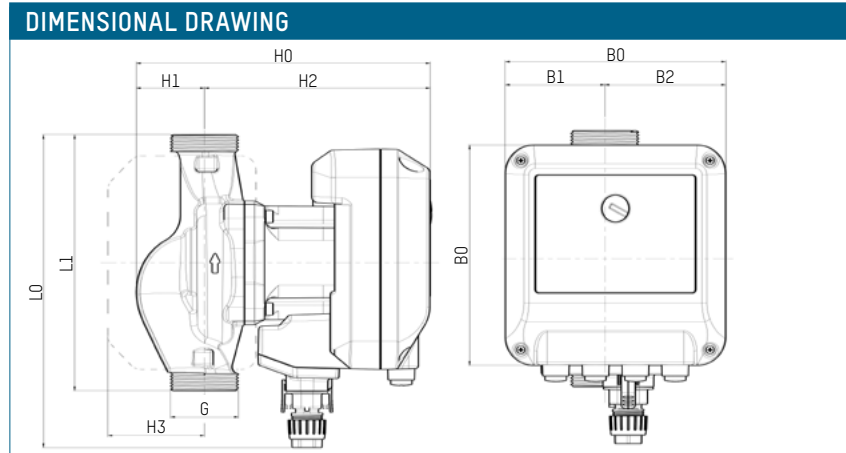

MEASUREMENT TABLE

Order no.	L0	L1	B0	B1	B2	H0	H1	H2	H3
302.5238.000	220	180	155	70	85	207	48	159	68
302.6238.000	220	180	155	70	85	207	48	159	68

ENERGY EFFICIENCY INDEX

EEI ≤ 0,22 - Part 2

Reference value for the most efficient circulation pump is EEI ≤ 0.20

PERFORMANCE CURVES

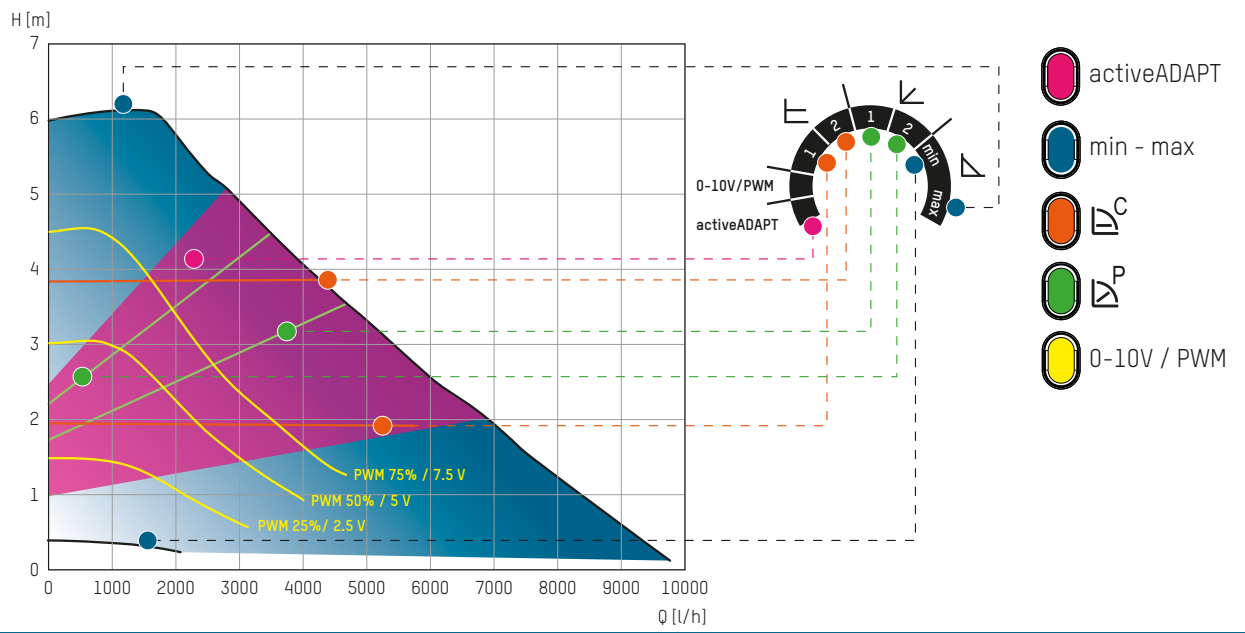

POWER CONSUMPTION CURVES

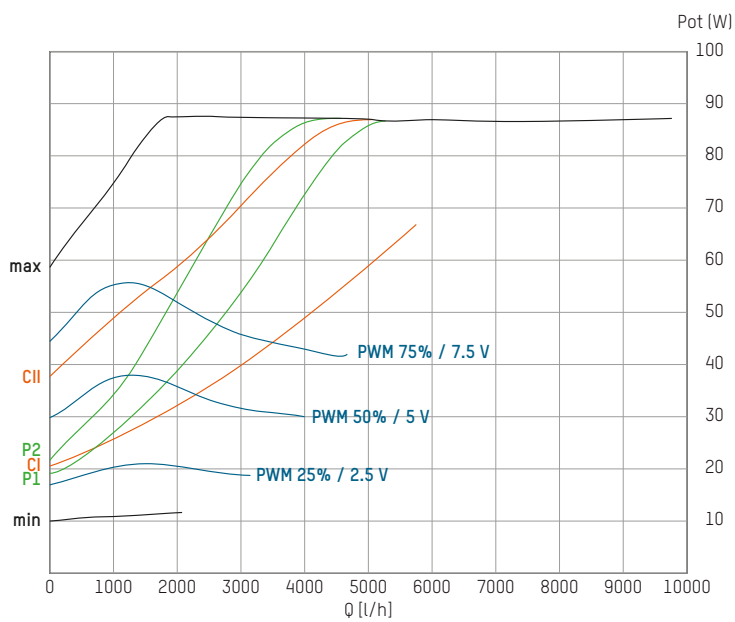

TACOFLOW3 MAX | HEATING AND COOLING CIRCUIT PUMPS

SPECIFICATION TEXT

See www.taconova.com

TECHNICAL DATA

Pump

- Ambient temperature: +0 °C to +40 °C
- Permissible temperature range: -10 °C to +110 °C
- Permissible temperature ranges at max. ambient temperature:
 - at 30 °C: +30 °C to +100 °C
 - at 40 °C: +40 °C to +70 °C
- Static pressure: Max. 1.0 MPa - 10 bar
- Minimum pressure at air intake:
 - 0.05 MPa (0.5 bar) at 80 °C
 - 0.15 MPa (1.5 bar) at 95 °C
- Max. relative humidity: ≤ 80%
- Sound pressure level: < 43 dB (A)
- Low Voltage Directive (2006/95/EC): Standards applied: EN 60335-1 and EN 60335-2-51
- EMC Directive (2004/108/EC); Standards applied: EN 61000-3-2, EN 61000-3-3
- Ecodesign Directive (2009/125/EC); Standards applied: EN 16297-1 and EN 16297-2
- Inputs/outputs: PWM, 0-10 VDC

Material

- Pump body: Cast iron, CDP-coated (EN-GJL-200)
- Impeller: Brass / Composite plastic
- Shaft: Ceramic
- Bearing: Graphite / Ceramic
- Rotor housing: Composite plastic

TECHNICAL DATA (CONTINUED)

Motor and electronics

- Supply voltage: 1x230 V (±10%), PE frequency: 50/60 Hz
- Power rating (P1): Min. 16 W, max. 122 W
- Rated current (I1): Min. 0.2 A, max. 0.8 A
- Insulation class: F
- Protection rating: IP 44
- Temperature class: TF 110

TYPE OVERVIEW

TacoFlow3 MAX | Heating and cooling circuit pumps
 Cast iron high efficiency pump with threaded and plug connection.
 Standard thermal insulation shell.
 Pump head: 8 m

TECHNICAL DATA (CONTINUED)

Fluids

- Heating water (VDI 2035; SWKI BT 102-01; ÖNORM H 5195-1)
- Water and proprietary additives used against corrosion and freezing up to 30 %

Order no.	Designation	G	Centre distance	Weight
302.5258.000	MAX 25-80/180	1 ½"	180 mm	3.5 kg
302.6258.000	MAX 32-80/180	2"	180 mm	3.5 kg

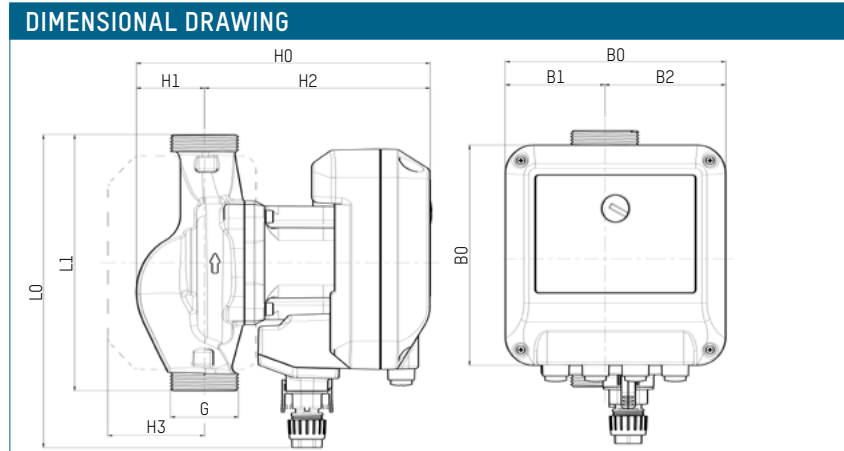

MEASUREMENT TABLE

Order no.	L0	L1	B0	B1	B2	H0	H1	H2	H3
302.5238.000	220	180	155	70	85	207	48	159	68
302.6238.000	220	180	155	70	85	207	48	159	68

ENERGY EFFICIENCY INDEX

EEI ≤ 0,22 - Part 2

Reference value for the most efficient circulation pump is EEI ≤ 0.20

PERFORMANCE CURVES

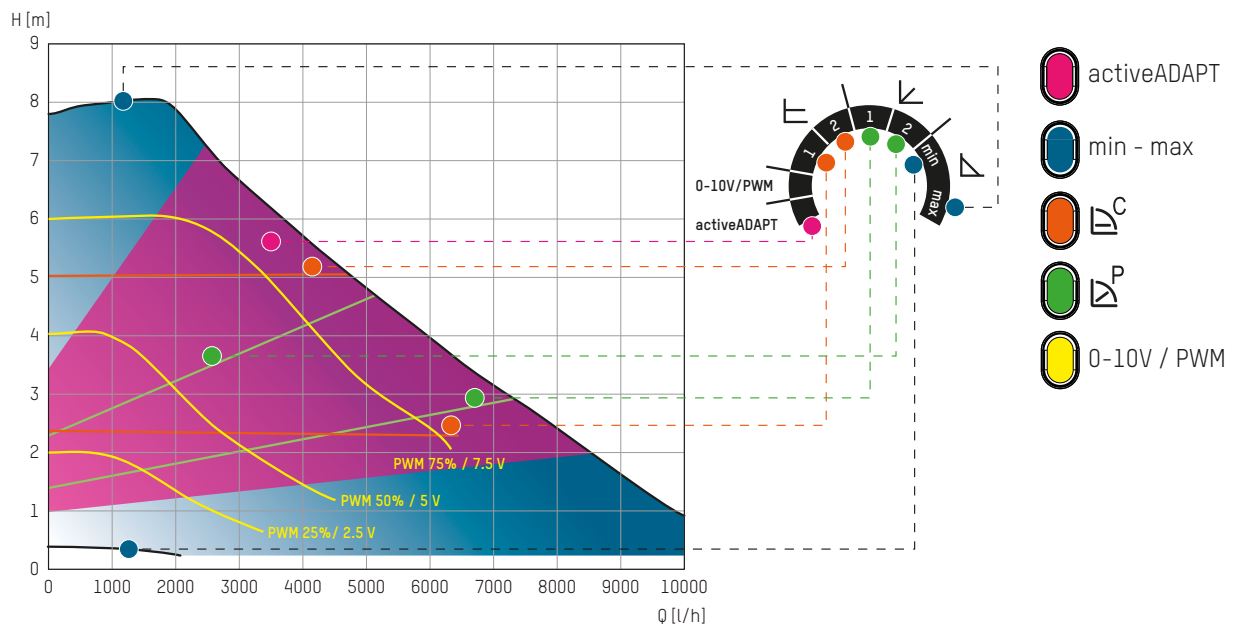

POWER CONSUMPTION CURVES

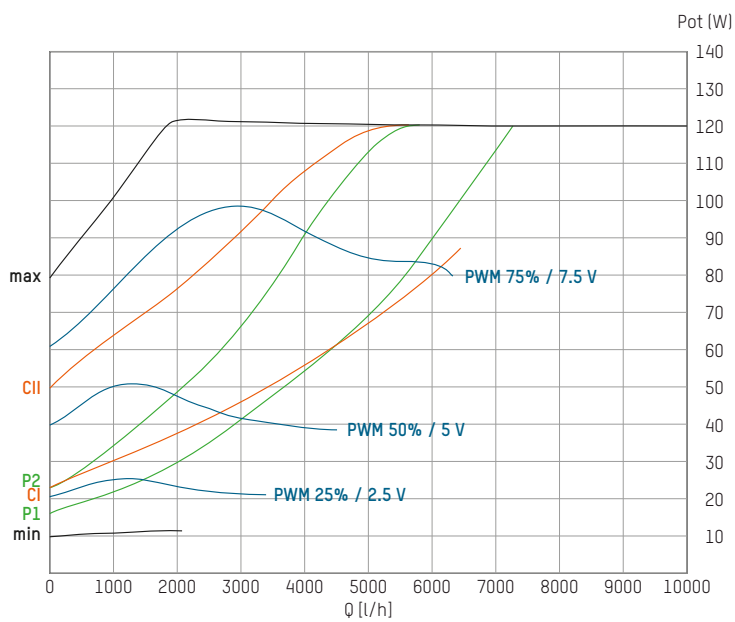

TACOFLOW3 MAX | HEATING AND COOLING CIRCUIT PUMPS

SPECIFICATION TEXT

See www.taconova.com

TECHNICAL DATA

Pump

- Ambient temperature: +0 °C to +40 °C
- Permissible temperature range: -10 °C to +110 °C
- Permissible temperature ranges at max. ambient temperature:
 - at 30 °C: +30 °C to +100 °C
 - at 40 °C: +40 °C to +70 °C
- Static pressure: Max. 1.0 MPa - 10 bar
- Minimum pressure at air intake:
 - 0.05 MPa (0.5 bar) at 80 °C
 - 0.15 MPa (1.5 bar) at 95 °C
- Max. relative humidity: ≤ 80%
- Sound pressure level: < 43 dB (A)
- Low Voltage Directive (2006/95/EC): Standards applied: EN 60335-1 and EN 60335-2-51
- EMC Directive (2004/108/EC); Standards applied: EN 61000-3-2, EN 61000-3-3
- Ecodesign Directive (2009/125/EC); Standards applied: EN 16297-1 and EN 16297-2
- Inputs/outputs: PWM, 0-10 VDC

Material

- Pump body: Cast iron, CDP-coated (EN-GJL-200)
- Impeller: Brass / Composite plastic
- Shaft: Ceramic
- Bearing: Graphite / Ceramic
- Rotor housing: Composite plastic

TECHNICAL DATA (CONTINUED)

Motor and electronics

- Supply voltage: 1x230 V (±10%), PE frequency: 50/60 Hz
- Power rating (P1): Min. 16 W, max. 175 W
- Rated current (I1): Min. 0.2 A, max. 0.9 A
- Insulation class: F
- Protection rating: IP 44
- Temperature class: TF 110

TYPE OVERVIEW

TacoFlow3 MAX | Heating and cooling circuit pumps
 Cast iron high efficiency pump with threaded and plug connection.
 Standard thermal insulation shell.
 Pump head: 10 m

TECHNICAL DATA (CONTINUED)

Fluids

- Heating water (VDI 2035; SWKI BT 102-01; ÖNORM H 5195-1)
- Water and proprietary additives used against corrosion and freezing up to 30 %

Order no.	Designation	G	Centre distance	Weight
302.5268.000	MAX 25-100/180	1 ½"	180 mm	3.5 kg
302.6268.000	MAX 32-100/180	2"	180 mm	3.5 kg

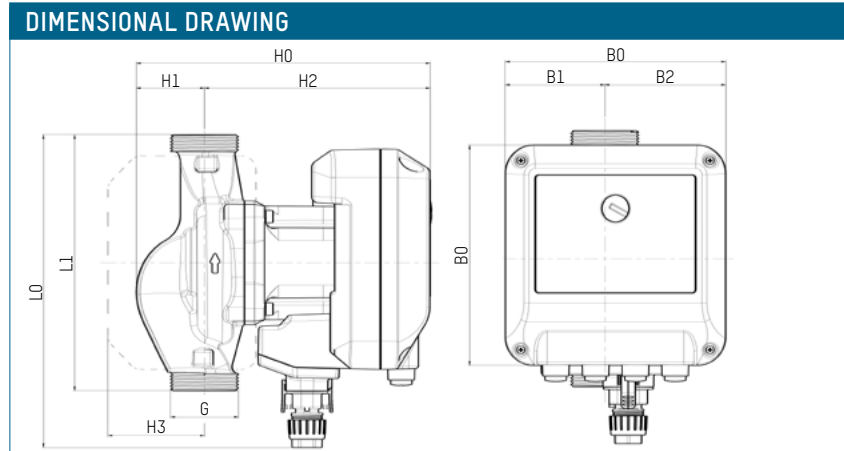

MEASUREMENT TABLE

Order no.	L0	L1	B0	B1	B2	H0	H1	H2	H3
302.5268.000	220	180	155	70	85	207	48	159	68
302.6268.000	220	180	155	70	85	207	48	159	68

ENERGY EFFICIENCY INDEX

EEI ≤ 0,22 - Part 2

Reference value for the most efficient circulation pump is EEI ≤ 0.20

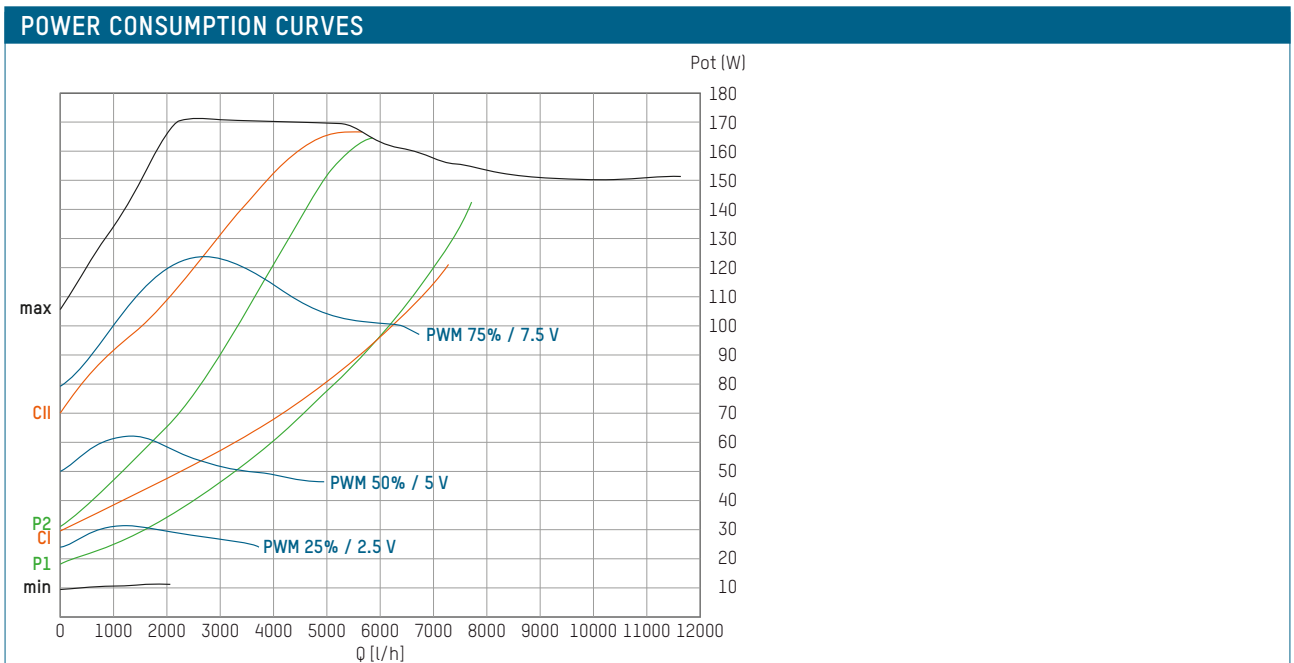
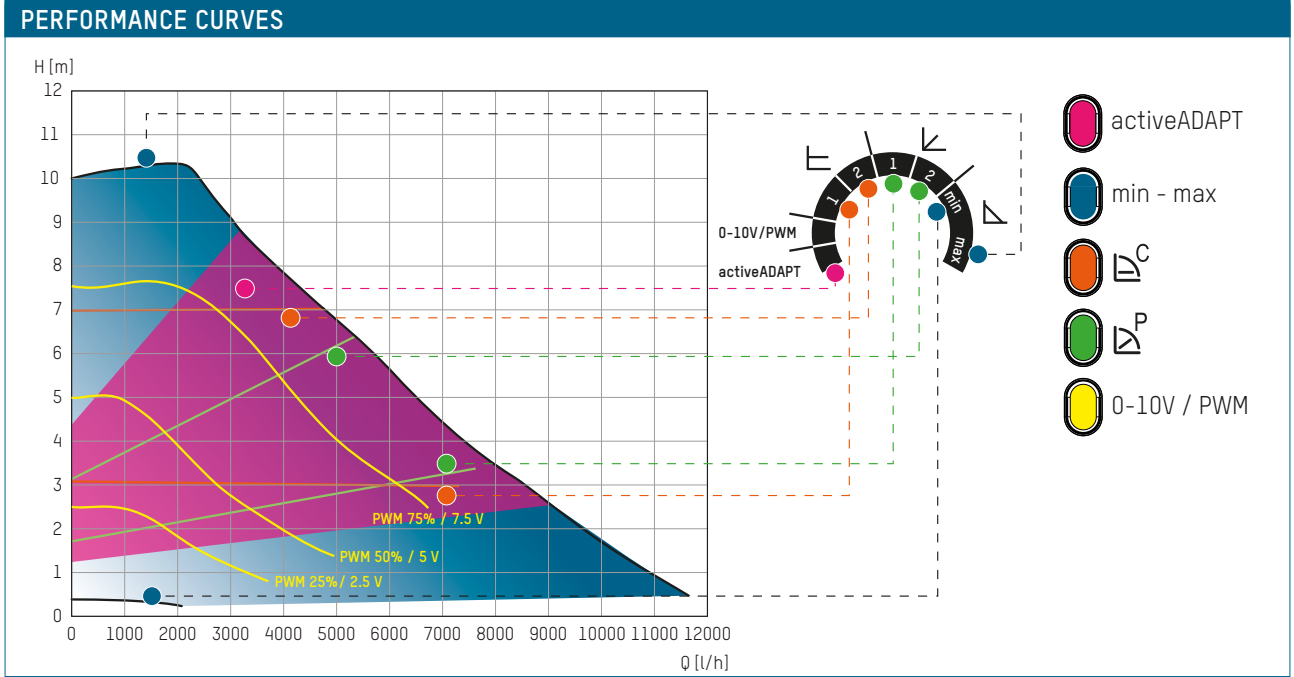

Cerbos

küttesüsteemid • müük • paigaldus • hooldus

tel +372 442 0222 / +372 434 1000 • www.cerbos.ee • info@cerbos.ee